









	Serie	Seite	Zylindergröße [inch] mm						Spannkraft mit Standardarm bei 6bar [87psi] N [lbf.]						Spannhub mm [inch]		
			[0.75 bis 1.00] 19 bis 25	[1.18 bis 1.26] 30 bis 32	[1.50 bis 1.57] 38 bis 40	[1.97] 50	[2.48] 63	[20 bis 27] 90 bis 120	[40 bis 52] 180 bis 230	[63 bis 72] 280 bis 320	[90 bis 105] 400 bis 470	[112 bis 117] 500 bis 520	[166 bis 195] 740 bis 870	[260 bis 300] 1170 bis 1330	[0.31 bis 0.39] 8 bis 10	[0.47 bis 0.63] 12 + bis 16	[0.78 bis 0.98] 20 bis 25
9500 	9522	11.3															
	9530	11.3															
	9540	11.3															
89R 	89R20-010-2	11.5															
	89R32-010-2	11.5															
	89R40-010-2	11.5															
	89R40-025-2	11.5															
	89R50-025-2	11.5															
	89R63-025-2	11.5															
89B 	89B20-010-1	11.7															
	89B30-010-1	11.7															
	89B40-010-1	11.7															
	89B50-025-1	11.7															
	89B63-008-1	11.7															
8100, 8300 	8115	11.7															
	8116	11.7															
	8315	11.7															
	8316	11.7															
89E 	89E20-010-1	11.11															
	89E30-010-1	11.11															
	89E40-010-1	11.11															
	89E50-025-1	11.11															
	89E63-008-1	11.11															

	Serie	Seite	Zylindergröße [inch] mm						Spannkraft mit Standardarm bei 6bar [87psi] N [lbf.]						Spannhub mm [inch]			
			[0.75 bis 1.00] 19 bis 25	[1.18 bis 1.26] 30 bis 32	[1.50 bis 1.57] 38 bis 40	[1.97] 50	[2.48] 63	[20 bis 27] 90 bis 120	[40 bis 52] 180 bis 230	[63 bis 72] 280 bis 320	[90 bis 105] 400 bis 470	[112 bis 117] 500 bis 520	[166 bis 195] 740 bis 870	[260 bis 300] 1170 bis 1330	[0.31 bis 0.39] 8 bis 10	[0.47 bis 0.63] 12 + bis 16	[0.78 bis 0.98] 20 bis 25	
8000, 8200, 8400 	8015	11.11	■					■								■		
	8016	11.11	■					■								■		
	8215	11.11			■					■							■	
	8216	11.11			■					■							■	
	8415	11.11		■							■						■	
	8416	11.11		■							■						■	
035-1 	035-125-190	11.15	■					■								■		
	035-125-290	11.15	■					■								■		
	035-132-190	11.15		■					■							■		
	035-132-290	11.15		■					■							■		
	035-140-190	11.15			■					■						■		
	035-140-290	11.15			■					■						■		
	035-150-190	11.15				■					■					■		
	035-150-290	11.15				■					■					■		
035-2 	035-225-190	11.15	■					■								■		
	035-225-290	11.15	■					■								■		
	035-232-190	11.15		■					■							■		
	035-232-290	11.15		■					■							■		
	035-240-190	11.15			■					■						■		
	035-240-290	11.15			■					■						■		
	035-250-190	11.15				■					■					■		
	035-250-290	11.15				■					■					■		

Serie 9500 Produktübersicht

Produktmerkmale:

- Kein Schwenkhub, dreht auf einer Ebene
- Kolbenstange immer vor Schweißspritzern geschützt
- Vielseitige Spannarmanbindung
- Keine externen Drosselrückschlagventile notwendig

International patentiert

Anwendungsbereiche:

- Schweißen
- Montieren
- Leichte maschinelle Bearbeitung

Außerdem verfügbar:

Zubehör siehe Seite 12.2 für Spannarme

Zubehör siehe Seite 13.1 für Sensoren

9522



9530



9540



Abb. mit Standard-Spannarm

Serie 9500 Technische Informationen

Modell	Gesamthub mm[in]	Schwenkrichtung	Gewicht kg[lb.]	Effektive Kolbenfläche zum Spannen cm ² [in. ²]	Luftvolumen schließen cm ³ [in. ³]	Luftvolumen öffnen cm ³ [in. ³]	Kolbenkraft bei 6bar[87PSI] N[lbf.]	Dichtsatz
9522L	[0.50] 13	LH	[0.94] 0,43	[0.61] 3,90	[0.61] 10	[0.76] 12,5	[53] 235	952290
9522R		RH						
9530L	[0.79] 20	LH	[1.38] 0,63	[1.03] 6,65	[1.33] 21,8	[1.58] 25,9	[90] 400	953090
9530GL								
9530R		RH						
9530GR								
9540L	[0.79] 20	LH	[2.13] 0,97	[1.84] 11,87	[2.36] 38,8	[2.69] 44	[160] 711	954090
9540GL								
9540R		RH						
9540GR								

Drehwinkel: 90°±5°

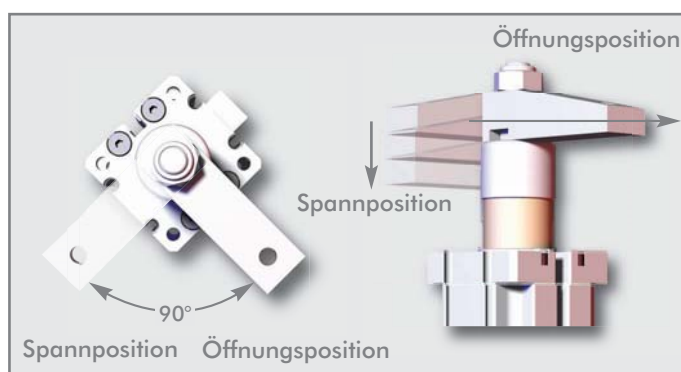
Wiederholgenauigkeit: ±1°

Betriebsdruck Bereich: 3bar[40psig] bis 8bar[120psig]

Max. Betriebstemperatur: 60°C[140°F]

Serie 9500 Abmessungen, Spannkraft

Serie 9522 Kolbenkraft

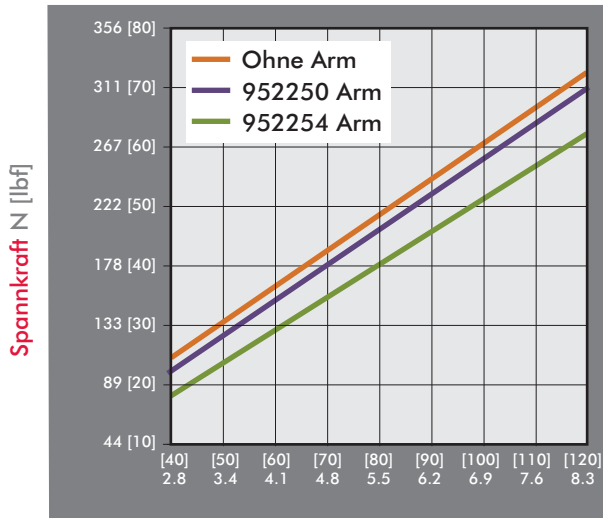

Betriebsdruck bar [psi]

Serie 9540 Kolbenkraft

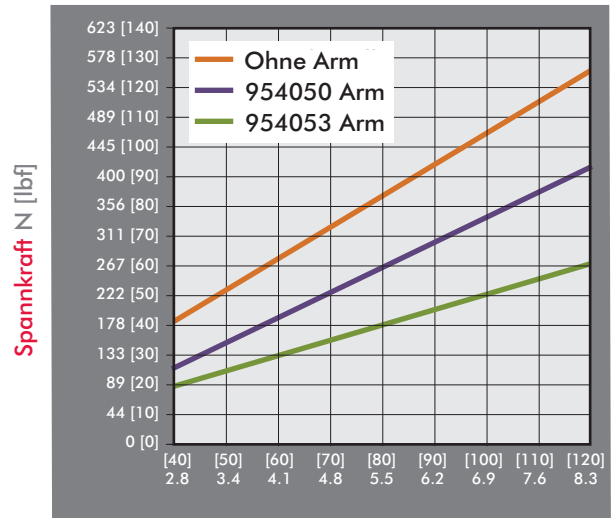

Betriebsdruck bar [psi]

Serie 9530 Kolbenkraft

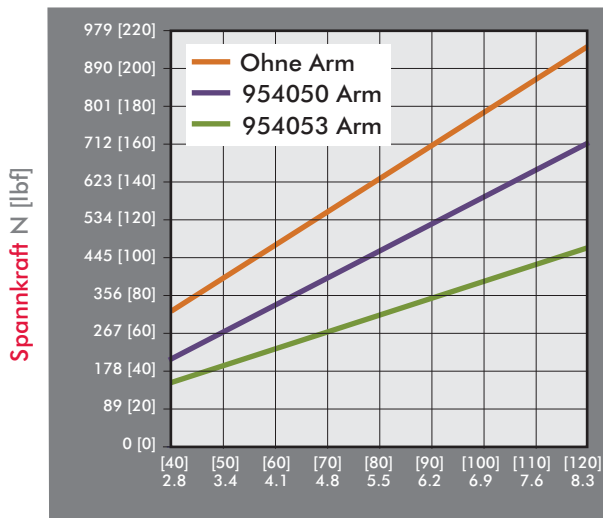

Betriebsdruck bar [psi]

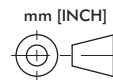
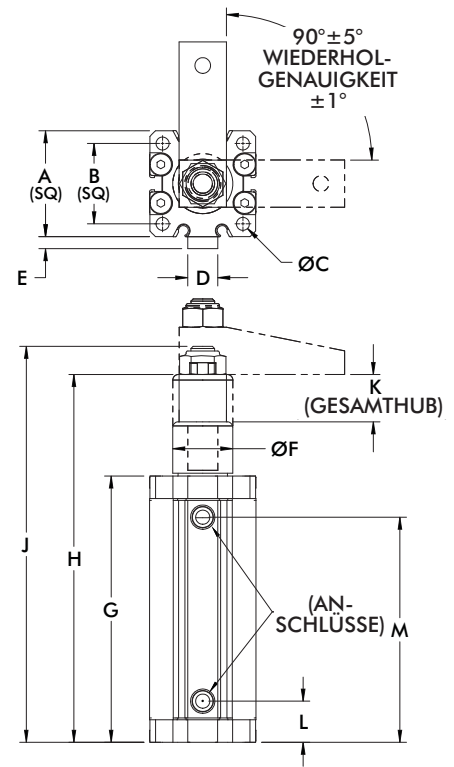

Modell	A	B	C	D	E	F	G	H	J	K	L	M	N
9522	[1.42] 36	[1.00] 25,4		--	--	[0.88] 22	[4.00] 102	[4.56] 116	[5.43] 138	[0.50] 13	[0.54] 14	[3.13] 80	M5
9530	[1.76] 44,7	[1.34] 34	[0.22] 5,5	[0.50] 12,7	[0.20] 5,1	[1.00] 25,4	[4.44] 112,7	[6.13] 155,7	[6.59] 167,3	[0.79] 20	[0.68] 17,4	[3.75] 95,3	1/8NPT
9530G													
9540	[2.05] 52	[1.57] 40		[0.63] 16	[0.35] 9	[1.14] 29	[4.78] 121,4	[6.50] 165	[6.94] 176,2		[0.84] 21,3	[3.97] 100,8	1/8NPT
9540G													G-1/8

Serie 89R Produktübersicht
Produktmerkmale:

- Einstellbare Schwenkrichtung links, rechts und linear. (Baugröße Ø 20mm ist nicht linear einstellbar)
- Unterschiedliche Sensornuten für Ø4mm und 6,5 x 5mm Sensoren
- Robust und leicht, geeignet für einige Millionen Arbeitszyklen
- Spannarm muß separat bestellt werden

Anwendungsbereiche:

- Schweißen
- Montieren
- Leichte maschinelle Bearbeitung

Außerdem verfügbar:

Zubehör Seite 12.2 - 12.5 für Spannarme und Befestigungszubehör
Zubehör Seite 13.1 für Sensor Optionen

89R

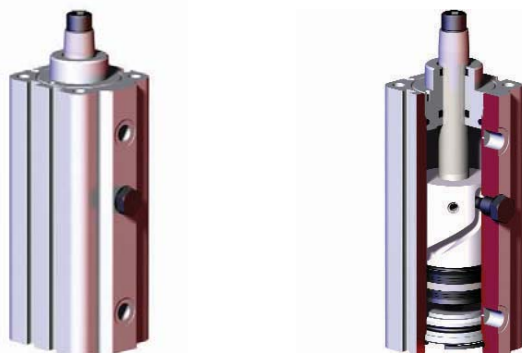

Sensoren sind optional.

 Bei Bestellung mit Sensor (2) 8EA-109-1, bitte am Ende **A** hinzufügen. Z.B.: 89R32-010-2**A**
Serie 89R Technische Informationen

Modell	Gesamthub mm[in]	Schwenkhub mm[in]	Spannhub mm[in]	Kolben Ø mm[in]	Luftvolumen schließen cm³[in.³]	Luftvolumen öffnen cm³[in.³]	Kolbenkraft bei 6bar[87PSI] N[lbf.]†	Gewicht kg[lb.]	Dichtsatz
89R20-010-2	[0.83] 21	[0.43] 11		[0.79] 20	[0.03] 4,9	[0.40] 6,6	[22] 96	[0.66] 0,30	89R20-00
89R32-010-2	[1.10] 28	[0.61] 18	[0.39] 10	[1.26] 32	[1.18] 19,4	[1.37] 22,5	[67] 300	[1.32] 0,60	89R32-00
89R40-010-2	[1.24] 31,5	[0.85] 21,5		[1.57] 40	[2.03] 33,3	[2.42] 39,6	[103] 456	[2.09] 0,95	89R40-00
89R40-025-2	[1.83] 46,5				[3.00] 49,1	[3.57] 58,4		[2.43] 1,10	
89R50-025-2	[2.05] 52	[1.06] 27	[0.98] 25	[1.97] 50	[5.42] 88,9	[6.23] 102,1	[167] 744	[3.97] 1,80	89R50-00
89R63-025-2	[2.30] 58,5	[1.32] 33,5		[2.48] 63	[11.13] 164	[11.13] 182,4	[263] 1170	[6.17] 2,80	89R63-00

† mit Standardspannarm

Drehwinkel: 90°±5°

Betriebsdruck Bereich: 2bar[30psig] bis 10bar[145psig]

Serie 89R Abmessungen, Spannkraft

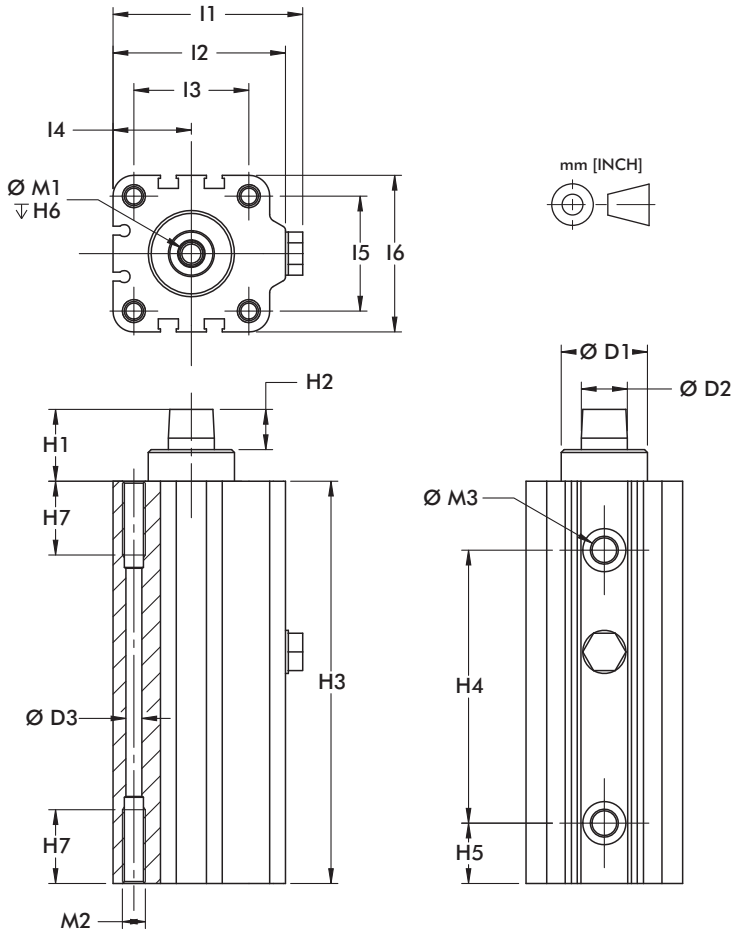

Serie 89R Kolbenkraft
(mit Standardspannarm)

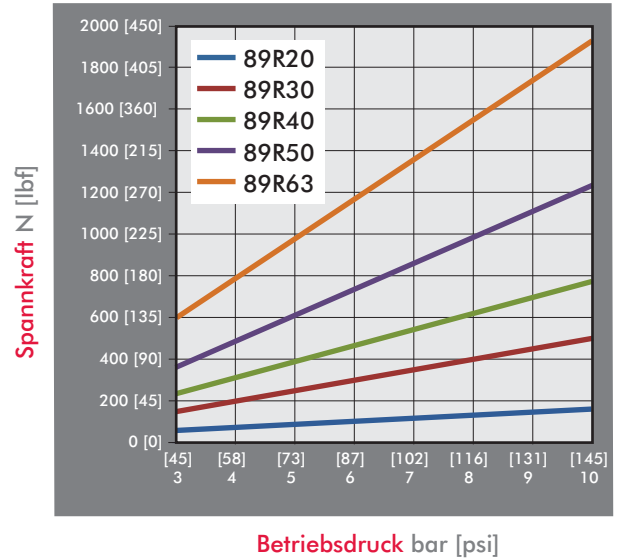

Betriebsdruck bar [psi]

Modell	ØD1	ØD2	ØD3	H1	H2	H3	H4	H5	H6	H7	L1	L2
89R20-010-2	[0.71] 18	[0.39] 10	[0.18] 4,6	[0.78] 19,8	[0.32] 8	[4.15] 105,5	[2.60] 66	[0.52] 13,2	[0.59] 15	[0.55] 14	[1.56] 39,5	[1.38] 35
89R32-010-2	[0.87] 22	[0.47] 12		[0.93] 23,7		[4.92] 125	[3.27] 83	[0.69] 17,5		[0.63] 16	[2.36] 60	[2.13] 54
89R40-010-2	[1.18] 30	[0.63] 16	[0.22] 5,5	[0.98] 25	[0.43] 11	[5.51] 140	[3.74] 95	[0.83] 21	[0.67] 17		[2.60] 66	[2.36] 60
89R40-025-2						[6.69] 170	[4.92] 125			[0.98] 25		
89R50-025-2	[1.57] 40	[0.71] 18	[0.29] 7,4	[1.24] 31,4		[7.70] 195,5	[5.39] 137	[1.05] 26,7	[0.98] 25		[3.09] 78,5	[2.85] 72,5
89R63-025-2	[1.77] 45	[0.78] 20	[0.37] 9,3	[1.30] 33	[0.59] 15	[8.33] 211,5	[6.08] 154,5	[1.04] 26,5			[3.74] 95	[3.46] 88

Modell	L3	L4	L5	L6	M1	M2	M3
89R20-010-2	[0.87] 22	[0.63] 16	[0.87] 22	[1.26] 32	M5	M6	M5
89R32-010-2	[1.42] 36	[0.94] 24	[1.26] 32	[1.77] 45	M6		
89R40-010-2	[1.57] 40	[1.07] 27,3	[1.57] 40	[2.15] 54,5	M8	M8	G-1/8
89R40-025-2							
89R50-025-2	[1.57] 40	[1.28] 32,5	[2.56] 65		M10	M10	
89R63-025-2	[2.44] 62	[1.57] 40	[3.15] 80		M10	M12	G-1/4

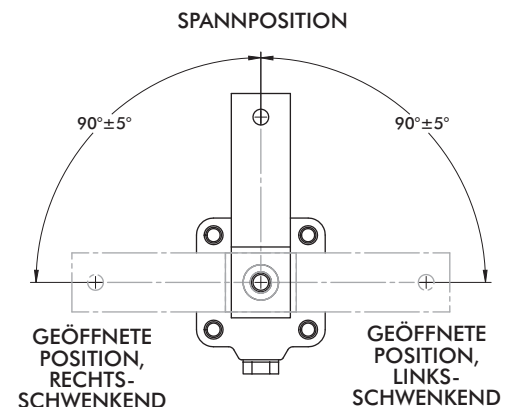

Serie 89B, 8100, 8300 Produktübersicht

Produktmerkmale:

- Kompakte Bauweise, hohe Zuverlässigkeit
- Leicht und robust, ausgelegt für mehrere Millionen Arbeitszyklen
- Kann von oben oder seitlich montiert werden

Anwendungsbereiche:

- Schweißen
- Montieren
- Leichte maschinelle Bearbeitung

Außerdem verfügbar:

Zubehör siehe Seite 12.2 - 12.5 für Spannarme und Befestigungszubehör
 Siehe Seite 13.1 für Sensor Optionen

Serie 89B ■

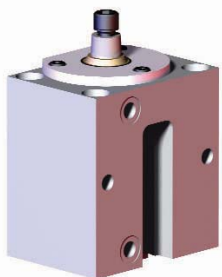

Verfügbar in Zylindergröße 20, 30, 40, 50, und 63mm.
 Sensoren sind optional.
 Bei Bestellung mit 2 Sensoren 8EA-109-1, bitte **A** am Ende der Modellnummer hinzufügen.
 Z.B.: 89B30-010-1R **A**
 Spannarm muß separat bestellt werden, siehe Seite 12.2 - 12.5

Serie 8100, 8300 ▲



Sensoren sind optional. Bei Bestellung mit 2 Sensoren 810169, bitte **A** am Ende der Modellnummer hinzufügen.
 Z.B.: 8115-A.
 Spannarm und Spindel sind im Lieferumfang.
 Bei Bestellung ohne Spannarm, bitte **-LA** am Ende der Bestellnummer hinzufügen.
 Z.B.: 8115-**LA**

Serie 89B, 8100, 8300 Technische Informationen

Modell	Schwenkrichtung	Gesamthub		Spannhub	Kolben Ø	Luftvolumen schließen	Luftvolumen öffnen	Kolbenkraft bei 6bar [87PSI] N[lbf.]†	Gewicht kg[lb.]	Dichtsatz
		mm[in]	mm[in]							
■ 89B20-010-1R	R	[0.79]	[0.39]		[0.79]	[0.29]	[0.38]	[22]	[1.70]	8940-3-00
■ 89B20-010-1L	L	20	10		20	4,71	6,28	97	0,77	
■ 89B30-010-1R	R	[0.83]	[0.43]	[0.39]	[1.18]	[0.76]	[0.91]	[63]	[2.43]	8945-3-00
■ 89B30-010-1L	L	21	11	10	30	12,47	14,85	280	1,10	
■ 89B40-010-1R	R	[0.94]	[0.55]		[1.57]	[1.55]	[1.84]	[103]	[3.26]	8950-3-00
■ 89B40-010-1L	L	24	14		40	25,34	30,16	460	1,48	
■ 89B50-025-1R	R	[1.57]	[0.59]	[0.98]	[1.97]	[4.17]	[4.79]	[194]	[5.73]	8952-3-00
■ 89B50-025-1L	L	40	15	25	50	68,37	78,55	865	2,6	
■ 89B63-008-1R	R	[1.02]	[0.71]	[0.32]	[2.48]	[4.45]	[4.95]	[298]	[6.24]	8955-3-00
■ 89B63-008-1L	L	26	18	8	63	72,89	81,06	1330	2,83	
▲ 8115	R	[0.85]	[0.47]	[0.38]	[0.75]	[0.25]	[0.38]	[25]	[0.68]	801560
▲ 8116	L	21,5	11,8	9,7	19,1	4,1	6,23	110	0,31	
▲ 8315	R	[1.25]	[0.75]	[0.50]	[1.50]	[2.01]	[2.26]	[89]	[2.00]	821560
▲ 8316	L	31,8	19,1	12,7	38,1	32,94	37,03	400	0,91	

† mit Standardspannarm Bevorzugte Märkte: ▲ Nord- Amerika/Süd- Amerika ■ Europa ● Global

Betriebsdruck Bereich:

89B: 3bar [30psig] bis 10bar [145psig] (**89B20** 8bar [116psig] max.)

8100, 8300: 3bar [30psig] bis 9bar [130psig]

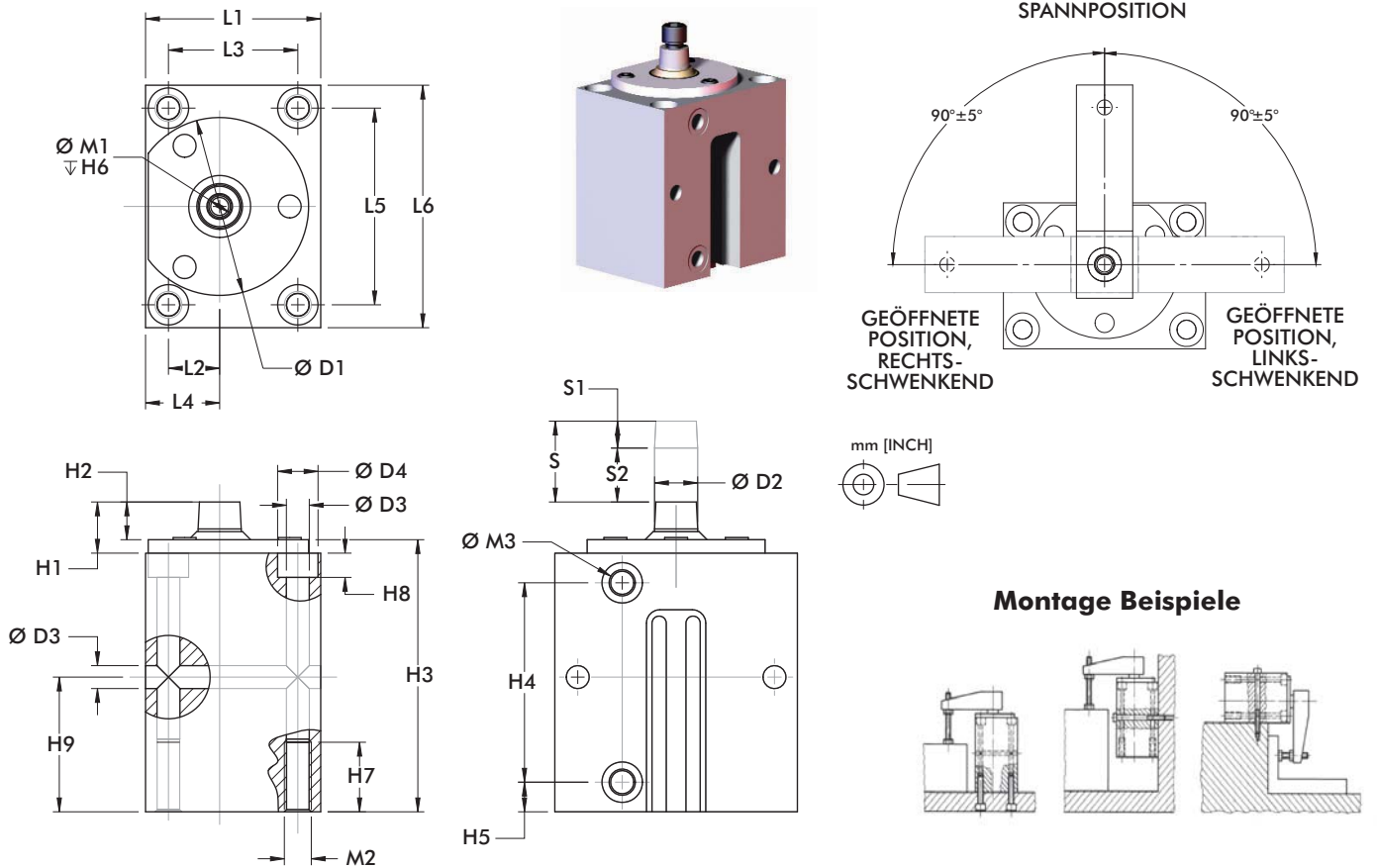

Modell	Ø D1	Ø D2	Ø D3	H1	H2	H3	H4	H5	H6	H7	L1	L2
89B20	[1.89] 48	[0.39] 10	[0.26] 6,6	[0.69] 17,5	[0.37] 9,5	[3.46] 88	[2.31] 58,7	[0.35] 9	[0.59] 15	[0.79] 20	[1.77] 45	[0.45] 11,5
89B32	[2.52] 64	[0.47] 12	[0.33]	[0.63] 16	[0.43] 11	[3.70] 94	[2.72] 69,2	[0.39] 10	[0.67] 17	[0.98]	[2.17] 55	[0.55] 14
89B40	[2.95] 75	[0.63] 16	8,5	[0.75] 19	[0.55] 14	[3.98] 101	[2.91] 74			25	[2.56] 65	[0.75] 19
89B50	[3.54] 90	[0.71] 18	[0.41]	[0.98] 25	[0.67] 17	[5.51] 140	[4.29] 109	[0.43] 11	[0.98] 25	[1.18]	[2.95] 75	[0.94] 24
89B63	[4.13] 105	[0.79] 20	10,5	[1.06] 27	[0.75] 19	[4.53] 115	[3.35] 85		[0.79] 20	30	[3.54] 90	[1.18] 30

Modell	L3	L4	L5	L6	M1	M2	M3
89B20	[1.18] 30	[0.75] 19	[2.36] 60	[2.95] 75	M5	M8	M5
89B32	[1.50] 38	[0.89] 22,5	[2.68] 68	[3.35] 85	M6	M10	
89B40	[1.89] 48	[1.08] 27,5	[2.87] 73	[3.54] 90	M8		G-1/8
89B50	[2.17] 55	[1.34] 34	[3.54] 90	[4.33] 110		M12	
89B63	[2.76] 70	[1.57] 40	[3.94] 100	[4.72] 120	M10		G-1/4

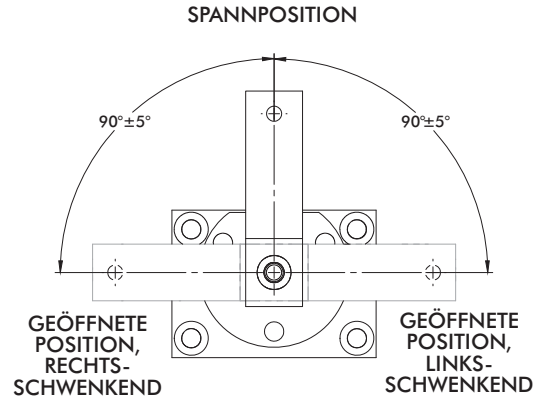
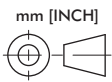
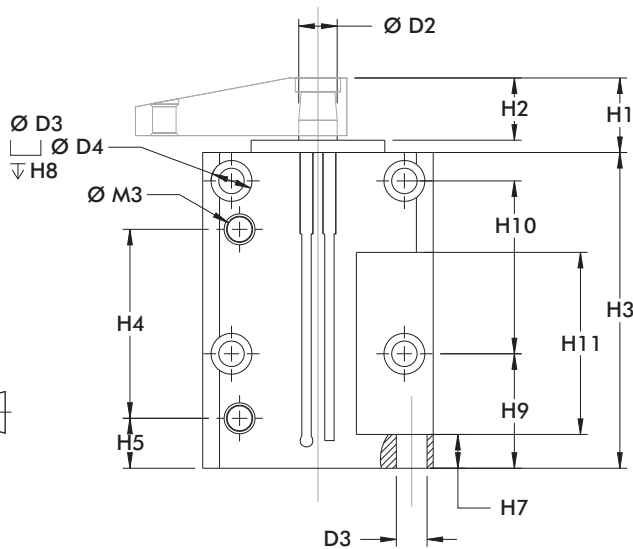
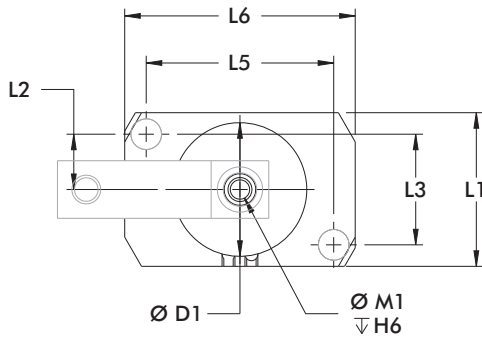
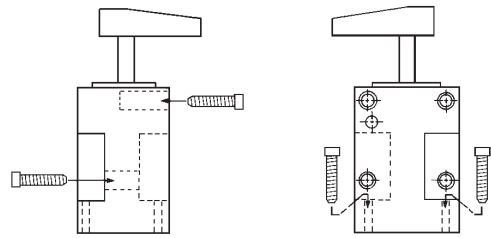
Serie 8100, 8300 Abmessungen

Montage Beispiele

Modell	Ø D1	Ø D2	Ø D3	Ø D4	H1	H2	H3	H4	H5	H6	H7	H8
8115	[1.23]	[0.44]	[0.20]	--	[0.53]	[0.41]	[3.37]	[1.45]	[0.35]	[0.75]	[0.25]	--
8116	31,2	11,2	5,1	--	13,5	10,4	85,6	36,8	8,9	19,1	6,4	--
8315	[1.74]	[0.50]	[0.33]	[0.53]	[0.97]	[0.81]	[4.11]	[2.46]	[0.65]	[0.67]	[0.44]	[1.00]
8316	44,2	12,7	8,4	13,5	24,6	20,6	104,4	62,5	16,5	17	11,2	25,4

Modell	H9	H10	H11	L1	L2	L3	L5	L6	M1	M3
8115	[1.37]	[1.00]	[1.00]	[1.25]	[0.47]	[0.94]	[0.94]	[1.25]	¼-20	#10-32
8116	34,8	25,4	25,4	31,8	11,9	23,9	23,9	31,8		
8315	[1.49]	[2.25]	[2.37]	[2.00]	[0.72]	[1.44]	[2.44]	[3.00]	5/16/18	1/8 NPT
8316	37,9	57,2	60,2	50,8	18,3	36,6	62	76,2		

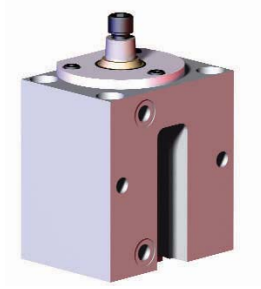
Serie 89B, 8100, 8300 Spannkraft



Serie 89B Kolbenkraft
(mit Standardspannarm)

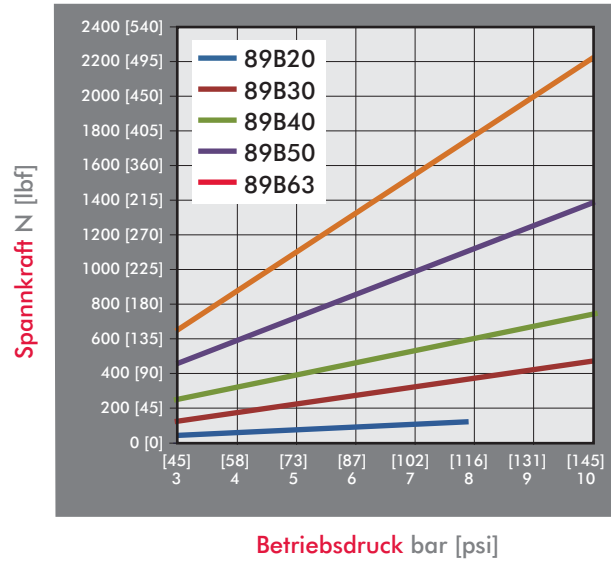

Serie 8100, 8300 Kolbenkraft
(mit Standardspannarm)

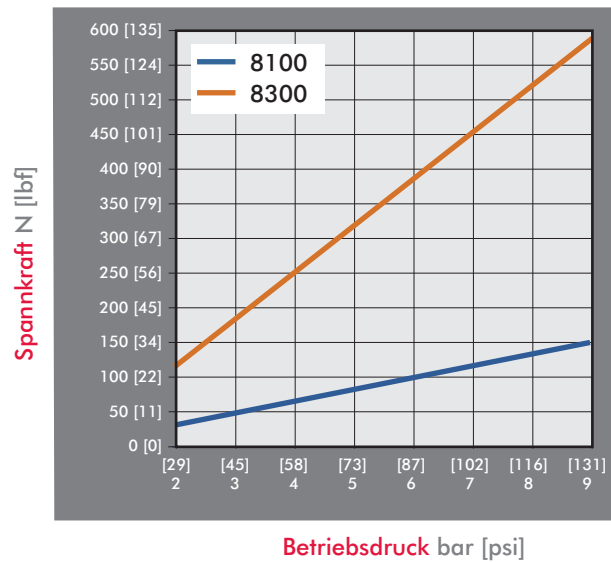

Serie 89E, 8000, 8200, 8400 Produktübersicht

Produktmerkmale:

- Kompakte Bauweise, hohe Zuverlässigkeit
- Leicht und robust, ausgelegt für mehrere Millionen Arbeitszyklen
- Gehäuse mit Außengewinde zum Einschrauben oder zur Montage mit Zubehör durch eine Montageplatte

Anwendungsbereiche:

- Schweißen
- Montieren
- Leichte maschinelle Bearbeitung

Außerdem verfügbar:

Zubehör siehe Seite 12.2 - 12.5 für Spannarme und Befestigungszubehör
 Siehe Seite 13.1 für Sensor Optionen

Serie 89E ■

Verfügbar in Zylindergröße 20, 30, 40, 50, und 63mm.
 Spannarm und Montagezubehör muß separat bestellt werden, siehe Seite 12.2 - 12.5

Serie 8000, 8200, 8400 ▲

Sensoren sind optional. Bei Bestellung mit 2 Sensoren 810169, bitte **A** am Ende der Modellnummer hinzufügen. Z.B.: 8215-**A**.

Spannarm und Spindel sind im Lieferumfang enthalten.

Bei Bestellung ohne Spannarm, bitte **-LA** am Ende der Bestellnummer hinzufügen. Z.B.: 8215-**LA**

Serie 89E, 8000, 8200, 8400 Technische Informationen

Modell	Schwenkrichtung	Gesamthub mm[in]	Schwenkhub mm[in]	Spannhub mm[in]	Kolben Ø mm[in]	Luftvolumen schließen cm ³ [in. ³]	Luftvolumen öffnen cm ³ [in. ³]	Kolbenkraft bei 6bar [87PSI] N[lbf.]	Gewicht kg[lb.]	Dichtsatz
■ 89E20-010-1R	R	[0.79]	[0.39]		[0.79]	[0.29]	[0.38]	[22]	[0.62]	8940-3-00
■ 89E20-010-1L	L	20	10		20	4,71	6,28	97	0,28	
■ 89E30-010-1R	R	[0.83]	[0.43]	[0.39]	[1.18]	[0.76]	[0.91]	[63]	[0.88]	8945-3-00
■ 89E30-010-1L	L	21	11	10	30	12,47	14,85	280	0,40	
■ 89E40-010-1R	R	[0.94]	[0.55]		[1.57]	[1.55]	[1.84]	[103]	[1.57]	8950-3-00
■ 89E40-010-1L	L	24	14		40	25,34	30,16	460	0,71	
■ 89E50-025-1R	R	[1.57]	[0.59]	[0.98]	[1.97]	[4.17]	[4.79]	[194]	[2.91]	8952-3-00
■ 89E50-025-1L	L	40	15	25	50	68,37	78,55	865	1,32	
■ 89E63-008-1R	R	[1.02]	[0.71]	[0.32]	[2.48]	[4.45]	[4.95]	[298]	[4.63]	8955-3-00
■ 89E63-008-1L	L	26	18	8	63	72,89	81,06	1,330	2,10	
▲ 8015	R	[0.85]	[0.47]	[0.38]	[0.75]	[0.25]	[0.38]	[25]		801560
▲ 8016	L	21,5	11,8	9,7	19,1	4,10	6,23	110		
▲ 8215	R				[1.50]	[2.01]	[2.26]	[89]	[1.69]	821560
▲ 8216	L	[1.25]	[0.75]	[0.50]	38,1	32,94	37,03	400	0,77	
▲ 8415	R	31,8	19,1	12,7	[1.19]	[1.17]	[1.42]	[68]		841560
▲ 8416	L				30,2	19,17	23,27	300		

† mit Standardspannarm Bevorzugte Märkte: ▲ Nord- Amerika/Süd- Amerika ■ Europa ● Global

Betriebsdruck Bereich:

89E: 3bar [30psig] bis 10bar [145psig] (**89E20** 8bar [116psig] max.)

8200, 8400: 3bar [30psig] bis 9bar [130psig]

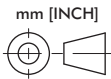
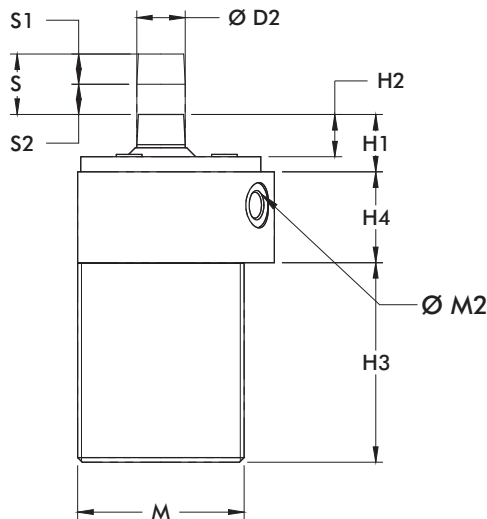
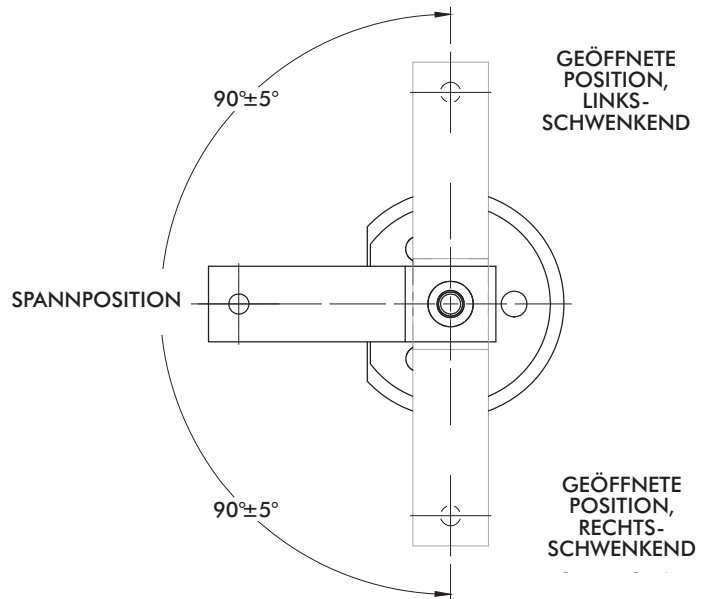
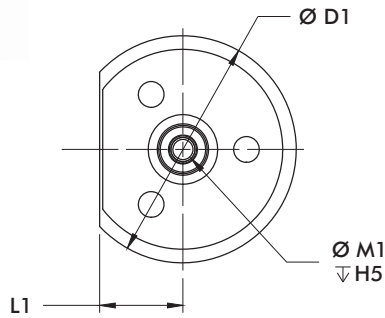

Montage Beispiele

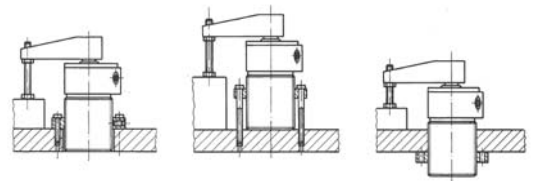

Modell	Ø D1	Ø D2	H1	H2	H3	H4	H5	L1	M	M1	M1
89E20	[1.89] 48	[0.39] 10	[0.69] 17,5	[0.37] 9,5	[2.36] 60	[1.10] 28	[0.59] 15	[0.75] 19	M36X1,5	M5	M5
89E32	[2.52] 64	[0.47] 12	[0.63] 16	[0.43] 11	[2.72] 69	[0.98] 25	[0.67] 17	[0.89] 22,5	M42X1,5	M6	G-1/8
89E40	[2.95] 75	[0.63] 16	[0.75] 19	[0.55] 14	[2.60] 66	[1.38] 35	17	[1.08] 27,5	M55X2	M8	
89E50	[3.54] 90	[0.71] 18	[0.98] 25	[0.67] 17	[4.09] 104	[1.50] 38	[0.98] 25	[1.36] 34,5	M68X2	M10	G-1/4
89E63	[4.13] 105	[0.79] 20	[1.06] 27	[0.75] 19	[3.03] 77	38	[0.79] 20	[1.57] 40	M80X2		

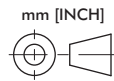
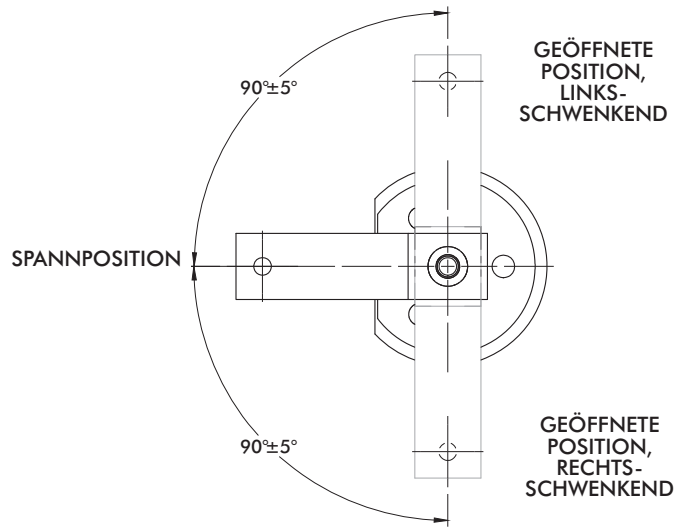
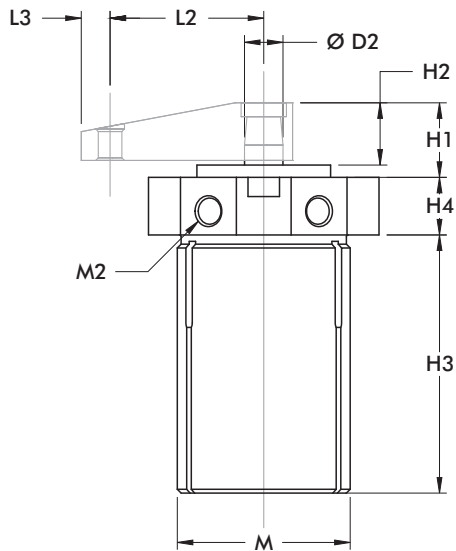
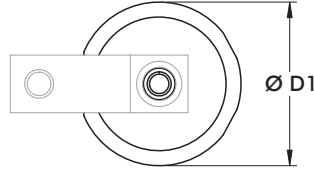
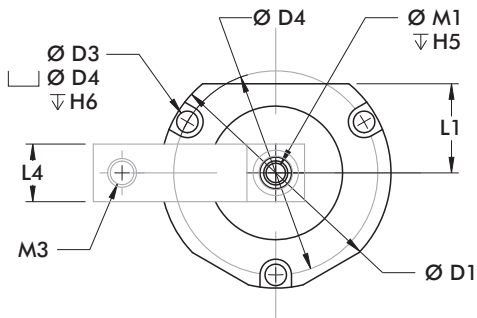
Serie 8000, 8200, 8400 Abmessungen

Modell	ØD1	ØD2	ØD3	ØD4	H1	H2	H3	H4	H5	H6	L1	L2
8015	[1.25]	[0.44]	--	--	[0.53]	[0.41]	[2.87]	[0.50]	[0.75]	--	--	[1.12]
8016	31,8	11,1	--	--	13,5	10,4	72,9	12,7	19,1	--	--	28,4
8215	[3.00]	[0.50]	[0.28]	[2.66]	[0.97]	[0.81]	[3.36]	[0.75]	[0.67]	[0.25]	[1.16]	[2.00]
8216	76,2		7,1	67,6	24,6	20,6	85,3			6,4	29,5	50,8
8415	[2.13]	12,7	--	--	[0.94]	[0.78]	[3.17]	19,1	17	--	--	[1.56]
8416	54,1		23,9	19,8	80,5	--	39,6					

Modell	L3	L4	M	M1	M2	M3
8015	[0.31]	[0.62]	1-1/8-16	1/4-20	#10-32	#10-32
8016	7,9	15,7				
8215	[0.38]	[0.75]	2-1/4-12	5/16-18	1/8 NPT	3/8-16
8216						
8415	9,6	19,1	1-3/4-12			
8416						

Serie 89E, 8000, 8200, 8400 Spannkraft

Serie 89E Kolbenkraft
(mit Standardspannarm)

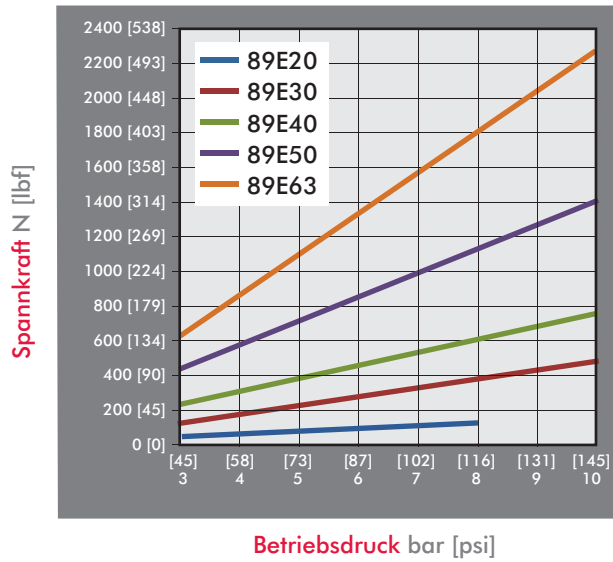

Serie 8000, 8200, 8400 Kolbenkraft
(mit Standardspannarm)

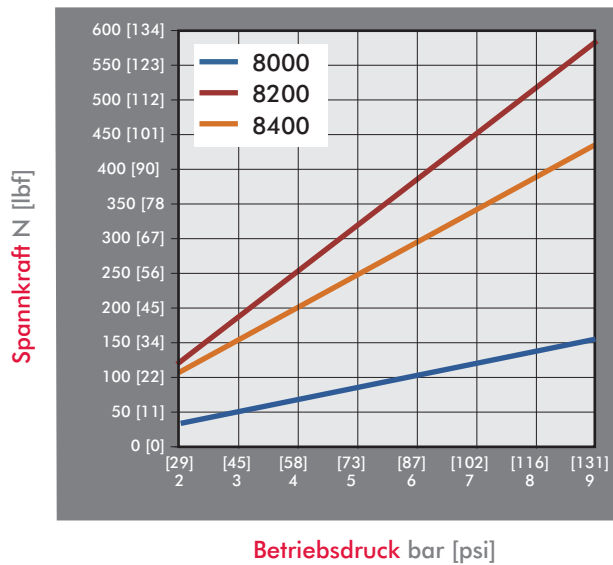

Serie 035 Produktübersicht

Produktmerkmale:

- Verfügbar mit Außengewinde oder mit niedriger Flanschbefestigung
- Kleine Bauweise
- Extra starke Spannarmbefestigung, verklemmt und verschraubt mit der Kolbenstange
- Verfügbar in Zylindergröße 25, 32, 40, und 50mm

Anwendungsbereiche:

- Schweißen
- Montieren
- Leichte maschinelle Bearbeitung

Außerdem verfügbar:

Zubehör siehe Seite 12.3 - 12.4 und 12.10 für Spannarme und Befestigungszubehör

Serie 035-1 ▲



Grundkörper mit Außengewinde zum Montieren durch die Vorrichtungslatte

Serie 035-2 ▲

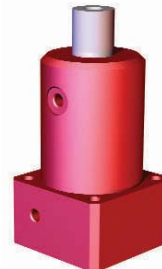

Grundkörper mit Flansch zur einfachen und schnellen Montage

Serie 035 Technische Informationen

Modell	Schwenkrichtung	Gesamthub mm[in]	Schwenkhub mm[in]	Spannhub mm[in]	Kolben Ø mm[in]	Luftvolumen schließen cm³[in.³]	Luftvolumen öffnen cm³[in.³]	Kolbenkraft bei 6bar [87PSI] N[lbf.]	Gewicht kg[lb.]	Dichtsatz
▲ 035-125-190	R	[1.04]	[0.51]	[0.53]	[0.98]	[0.54]	[0.79]	[27]	[0.56]	905516
▲ 035-125-290	L	26,3	12,8	13,5	25	8,87	12,92	120	0,25	
▲ 035-132-190	R	[1.13]	[0.56]	[0.57]	[1.26]	[1.06]	[1.41]	[40]	[0.94]	905517
▲ 035-132-290	L	28,8	14,3	14,5	32	17,34	23,13	180	0,43	
▲ 035-140-190	R	[1.20]	[0.57]	[0.63]	[1.57]	[1.96]	[2.33]	[70]	[1.31]	905518
▲ 035-140-290	L	30,4	14,4	16	40	32,1	38,21	312	0,59	
▲ 035-150-190	R	[1.18]	[0.63]	[0.55]	[1.97]	[3.02]	[3.59]	[90]	[1.81]	905519
▲ 035-150-290	L	30	16	14	50	49,49	58,91	400	0,82	
▲ 035-225-190	R	[1.05]	[0.54]	[0.51]	[0.98]	[0.55]	[0.80]	[27]	[0.56]	905516
▲ 035-225-290	L	26,7	13,7	13	25	9	13,11	120	0,25	
▲ 035-232-190	R	[1.06]	[0.57]	[0.49]	[1.26]	[0.99]	[1.32]	[40]	[1.13]	905517
▲ 035-232-290	L	26,8	14,4	12,4	32	16,17	21,56	180	0,51	
▲ 035-240-190	R	[1.09]	[0.57]	[0.52]	[1.57]	[1.78]	[2.13]	[70]	[1.40]	905518
▲ 035-240-290	L	27,7	14,4	13,3	40	29,26	34,83	312	0,64	
▲ 035-250-190	R	[1.13]	[0.63]	[0.51]	[1.97]	[2.90]	[3.45]	[90]	[1.90]	905519
▲ 035-250-290	L	28,8	16	12,8	50	47,52	56,57	400	0,86	

† mit Standardspannarm Bevorzugte Märkte: ▲ Nord- Amerika/Süd- Amerika ■ Europa ● Global

Betriebsdruck Bereich:
7bar [100psig] max.

Applikation Note:

Wenn der Spannarm die Länge von 80,0mm[3.15in.] überschreitet, muß der Betriebsdruck reduziert Hinweis::

- 25mm Kolben Ø: 4,5bar [80 psi]
- 32/40mm Kolben Ø: 5,5 bar [80 psi]
- 50mm Kolben Ø: 7,0 bar [100 psi]

Serie 035 Abmessungen, Spannkraft



Serie 035-1

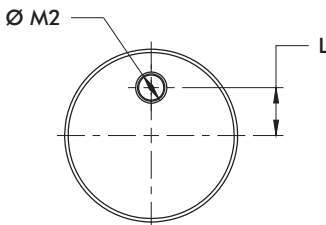
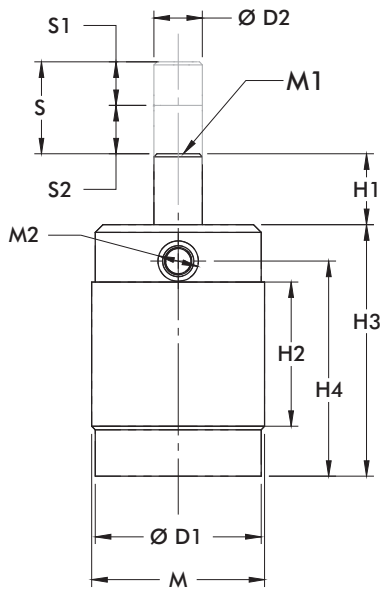

Serie 035-2

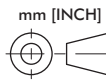
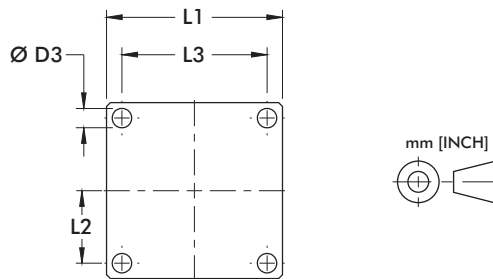
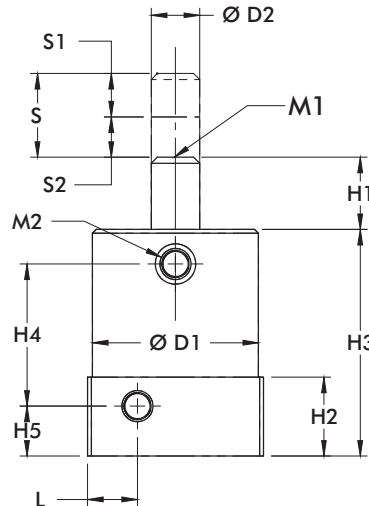

Serie 035 Kolbenkraft
(mit Standardspannarm)

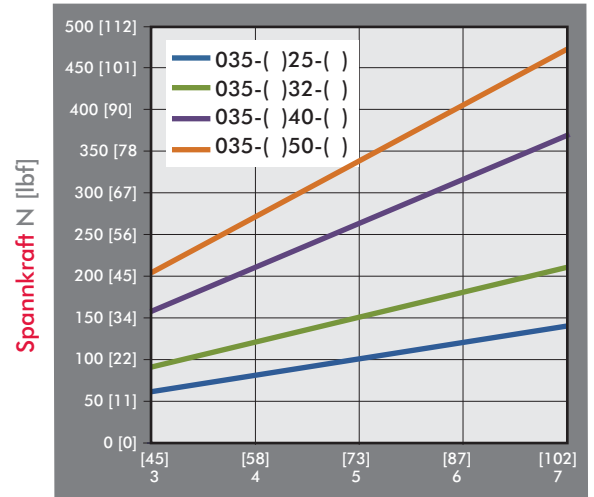

Betriebsdruck bar [psi]

Modell	ØD1	ØD2	H1	H2	H3	H4	H5	L	L1	L2	L3	M	M1	M1
035-125-()	[1.42] 36	[.55] 14	[0.57] 14,4	[1.50] 38,1	[2.76] 70	[2.25] 57,2	--	[0.35] 9	--	--	--	1-1/2 -16	1/4-20	#10-32
035-132-()	[1.79] 45,4	[0.63] 16	[0.75] 19,1	[1.72] 43,7	[3.87] 98,2	[2.63] 66,7	--	[0.45] 11,4	--	--	--	1-7/8-16	5/16-18	1/8 NPT
035-140-()	[2.16] 54,8	[0.79] 20	[0.76] 19,4	[1.88] 47,7	[3.28] 83,2	[2.80] 71	--	[0.70] 17,8	--	--	--	2-1/4-16	3/8-16	1/8 NPT
035-150-()	[2.36] 60	[0.79] 20	[0.70] 17,8	[2.00] 50,8	[3.48] 88,3	[2.95] 75	--	[0.50] 12,7	--	--	--	2-1/2-16	3/8-16	1/8 NPT
035-225-()	[1.38] 35	[.55] 14	[0.60] 15,2	[.91] 23	[2.62] 66,5	[1.60] 40,6	[0.50] 12,7	[0.57] 14,5	[1.57] 40	[0.61] 15,5	[1.22] 31	--	1/4-20	#10-32
035-232-()	[1.97] 50	[0.63] 16	[0.85] 21,6	[2.79] 71	[1.76] 44,6	[0.57] 114,5	[0.65] 16,5	[2.13] 54	[0.87] 22	[1.73] 44	--	5/16-18	1/8 NPT	1/8 NPT
035-240-()	[2.16] 54,8	[0.79] 20	[0.94] 23,9	[1.03] 26,1	[2.95] 75	[1.85] 47	[0.65] 16,5	[0.65] 16,5	[2.29] 58,2	[0.94] 24	[1.89] 48	--	3/8-16	1/8 NPT
035-250-()	[2.36] 60	[0.79] 20	[0.78] 19,7	[1.03] 26	[3.15] 80	[2.05] 52	[0.65] 16,5	[0.65] 16,5	[2.68] 68	[1.08] 27,5	[2.17] 55	--	3/8-16	1/8 NPT