

Parallel Grippers - Long Stroke Series

• Compact and robust design

This gripper is designed for use in confined spaces, combining long strokes with the high gripping force provided by two simultaneously acting pistons.

• For long finger applications:

Jaws are supported throughout the length of the body, enabling long fingers.

• Multipurpose gripper:

A wide range of options and accessories (safety springs, in-line jaws, magneto resistive or inductive sensors) allow these grippers to be used in a number of applications.

• Harsh environments:

Enclosed, shielded design repels chips and other particulate from internal drive mechanism.

• Spring assist, spring return:

Can be used as failsafe, single acting spring return, or double acting spring assist.

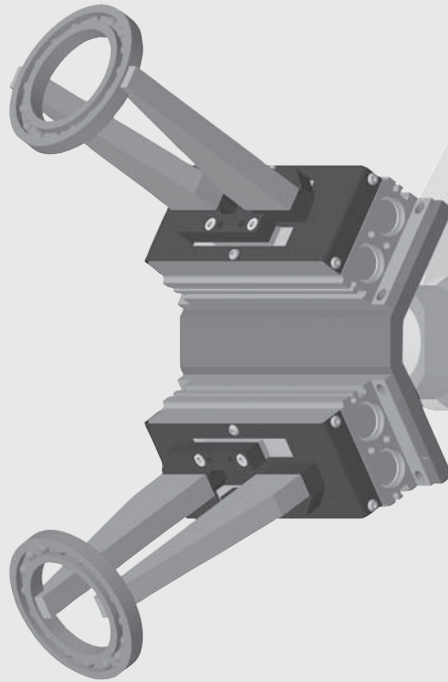

**NO
ADAPTER
PLATES!**

Mounting Information:

Gripper can be mounted and operated in any orientation

The gripper is protected from falling debris when it is mounted and operated upside down.

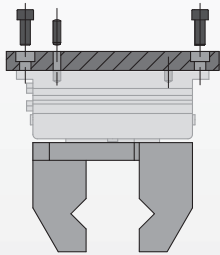

Gripper locates from the top with 2 dowel pins and can be assembled with 4 screws from the top or bottom.

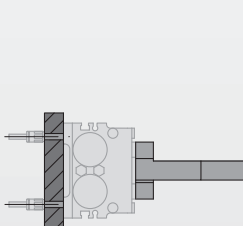
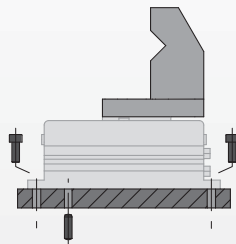

Gripper can be operated with rear inlets (manifold).

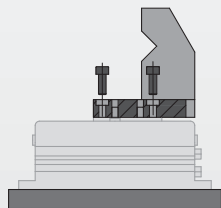

Fingers are located on jaws with 2 dowel pins and assembled with 2 screws.

Technical Specifications:

Pneumatic Specifications

Pressure Operating Range:

Standard
with **-R** Spring Option

Cylinder Type
Dynamic Seals
Valve Required
to Operate

Imperial

30-100 psi
60-100 psi

Metric

2-7 bar
4-7 bar

Double Acting

Internally Lubricated Buna-N

**4-way, 2-position for Double Acting
or 3-way, 2-position for Single Acting**

Air Quality Requirements

Air Filtration
Air Lubrication
Air Humidity

**40 Micron or Better
Not Necessary*
Low Moisture Content (dry)**

Temperature Operating Range

Buna-N Seals (Standard)

-4°~180° F

-20°~80° C

Maintenance Specifications†

Expected Life
Normal Application
w/ Preventative Maintenance
Field Repairable
Seal Repair Kits Available

**5 million cycles
10+ million cycles*
Yes
Yes**

*Addition of lubrication will greatly increase service life
† See Maintenance Section

Product Features

Quality Components

Made of aluminum alloy with Teflon™ impregnated hard coat anodize. The device's main components are made of heat treated steel.

Shielded Design

Gripper body is shielded to repel chips and other particulate from internal drive mechanism.

In-Line Jaws

Optional In-Line Jaws for simplified finger design: 2 interfaces can be fixed on to the jaws.

DIRECTCONNECT™ Mounting Patterns

DIRECTCONNECT™ mounting surface on back of body

Air Ports

Either lateral on 2 sides (couplings) or at the rear (manifold sealing).

Spring Assist

Option (-R) to restrain the component, should the air supply fail or to use the gripper in single acting mode by clamping on the shaft or the bore.

Magnetic Sensor

Piston is equipped with the magnet and the body has mounting slots.

Inductive Sensor Mounting Kit

Mounting kit has 2 flags and 3 adjustable sensor holders.

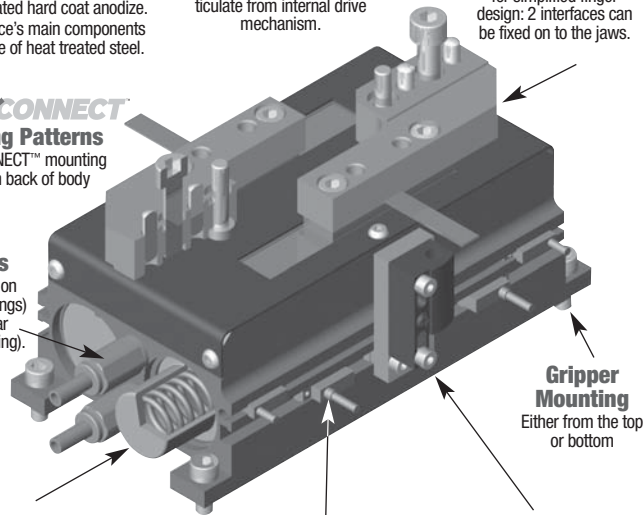

Gripper Mounting

Either from the top or bottom

Operating Principle

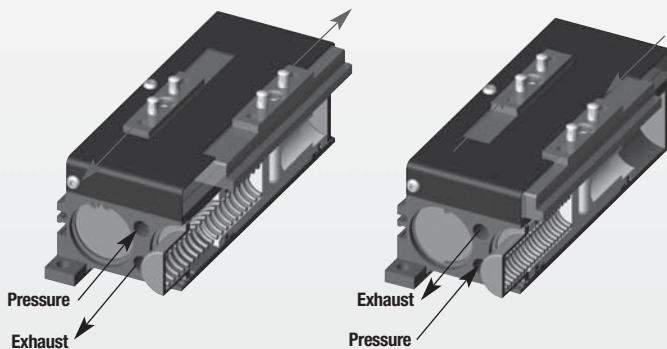
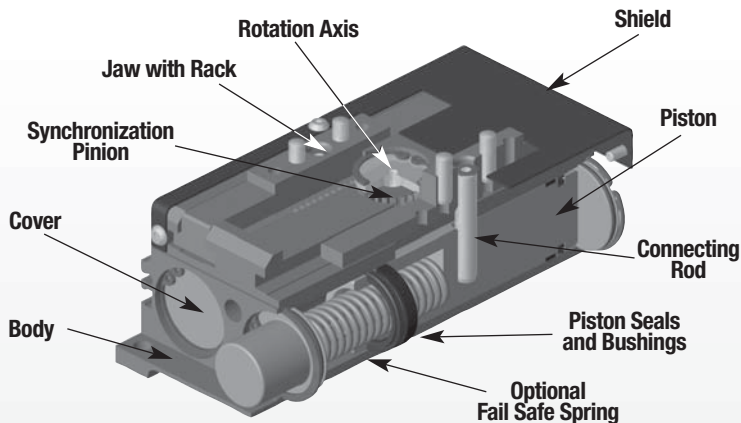

- Dual double acting pistons connected to both jaws and synchronized by the pinion actuate in opposite directions.
- Each jaw is guided by a T-slot in the body.
- Jaw Synchronization is achieved by a rack and pinion system.
- For Non-Synchronous operation, the pinion can be removed.
- Suitable for internal or external gripping.

Style -DPL Parallel Gripper

Size -2520

Style:	DPL-2520	
Stroke:	1.57 in.	40 mm
Grip Force:	182 lbs.	811 N
Weight:	3.04 lbs.	1.38 Kg



See Page **1.160**

Style -DPL Parallel Gripper

Size -2535

Style:	DPL-2535	
Stroke:	2.76 in.	70 mm
Grip Force:	173 lbs.	768 N
Weight:	3.97 lbs.	1.80 Kg



See Page **1.161**

Style -DPL Parallel Gripper

Size -3230

Style:	DPL-3230	
Stroke:	2.36 in.	60 mm
Grip Force:	306 lbs.	1359 N
Weight:	4.98 lbs.	2.26 Kg

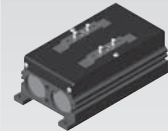

See Page **1.162**

Style -DPL Parallel Gripper

Size -3250

Style:	DPL-3250	
Stroke:	3.94 in.	100 mm
Grip Force:	294 lbs.	1306 N
Weight:	6.66 lbs.	3.02 Kg

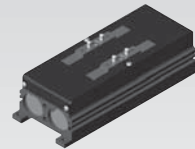

See Page **1.163**

Style -DPL Parallel Gripper

Size -4040

Style:	DPL-4040	
Stroke:	3.15 in.	80 mm
Grip Force:	457 lbs.	2035 N
Weight:	9.48 lbs.	4.30 Kg

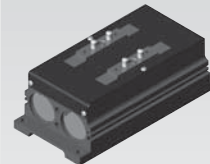

See Page **1.164**

Style -DPL Parallel Gripper

Size -4070

Style:	DPL-4070	
Stroke:	5.51 in.	140 mm
Grip Force:	456 lbs.	2029 N
Weight:	13.23 lbs.	6.00 Kg

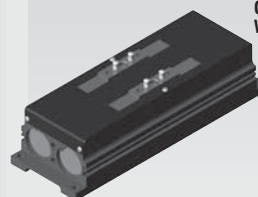

See Page **1.165**





PARALLEL GRIPPER DPL-2520 TWO JAW LONG STROKE

DPL SERIES

1.160

Specifications

	DPL-2520	
Total Rated Grip Force F @ 100 psi, 7 bar*	182 lbs.	811 N
Stroke	1.57 in	40 mm
Weight	3.04 lbs.	1.38 kg
Pressure Range (without springs)	30-100 psi	2-7 bar
Pressure Range (with springs)	60-100 psi	4-7 bar
Cylinder Bore Ø	0.98 in.	25 mm
Displacement	2.38 in ³	39 cm ³
Temperature Range	-4°~180° F	-20°~80° C
Actuation (open/close)	0.3/0.3 sec.	
Accuracy	±0.003 in.	±0.08 mm
Repeatability	±0.0010 in.	±0.025 mm.
Valve required to actuate single acting	3-way 2-position	
Valve required to actuate double acting	4-way, 2-position	

* With springs.

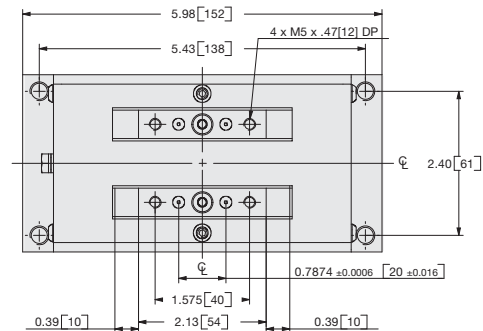
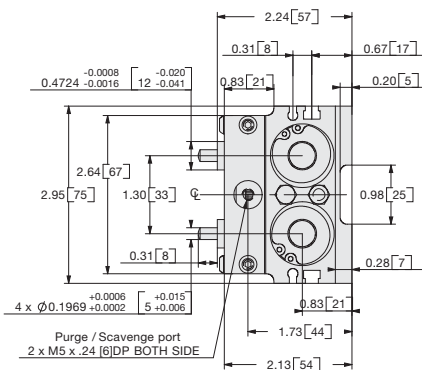
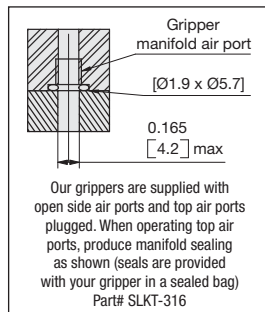
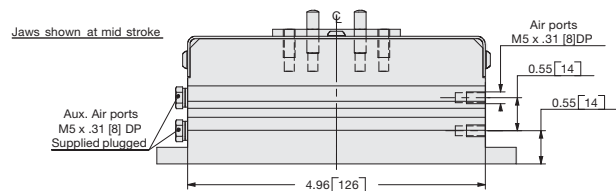
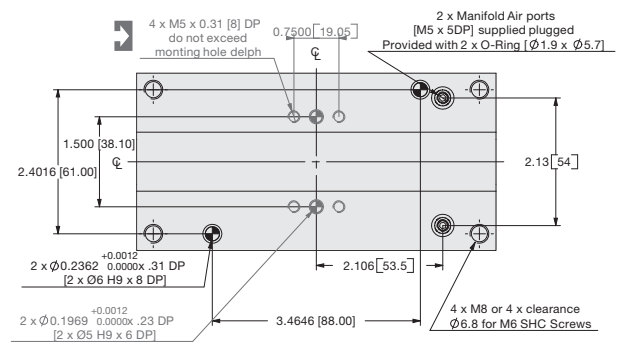

UNLESS OTHERWISE NOTED ALL TOLERANCES ARE AS SHOWN BELOW

- Dimensions are symmetrical about centerline
- Third Angle Projection
- All Dowel Holes are SF (Slip Fit). Locational Tolerance ±.0005" or [±.013mm]
- Metric Threads Course Pitch

Loading Information

How to Order: (Order Accessories separately from Basic Model)

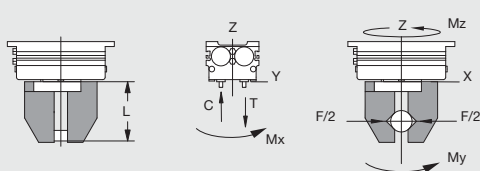
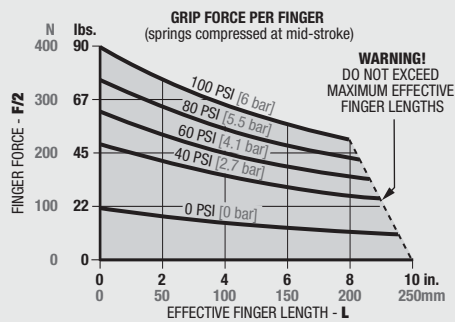

Loading Capacity [†]	Static		Dynamic	
	Imperial	Metric	Imperial	Metric
Maximum Tensile T	225 lbs.	1000 N	34 lbs.	150 N
Maximum Compressive C	283 lbs.	1260 N	34 lbs.	150 N
Maximum Moment M_x	372 in.-lbs.	42 Nm	35 in.-lbs.	4 Nm
Maximum Moment M_y	885 in.-lbs.	100 Nm	81 in.-lbs.	9 Nm
Maximum Moment M_z	531 in.-lbs.	60 Nm	81 in.-lbs.	9 Nm

[†]Capacities are per set of jaws and are not simultaneous

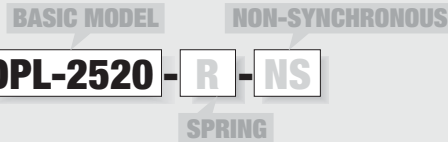

SENSOR ACCESSORIES*

	ORDER #	QTY/UNIT
PNP Magneto Resistive Sensor Long Barrel w/Qk Disc*	OHSP-017	1 to 3
NPN Magneto Resistive Sensor Long Barrel w/Qk Disc*	OHSN-017	1 to 3
PNP Magneto Resistive Sensor 90° Barrel w/Qk Disc*	OHSP-011	1 to 3
NPN Magneto Resistive Sensor 90° Barrel w/Qk Disc*	OHSN-011	1 to 3
Inductive Sensor Mounting Kit (3 Holders + 2 Flags)	OSMK-099	1
M8 PNP Inductive Sensor with Quick Disconnect*	OISP-011	1 to 3
M8 NPN Inductive Sensor with Quick Disconnect*	OISN-011	1 to 3
Quick Disconnect 2 Meter Cable Length*	CABL-010	1 to 3
Quick Disconnect 5 Meter Cable Length*	CABL-013	1 to 3

PNEUMATIC ACCESSORIES

	ORDER #	QTY/UNIT
Standard Seal Repair Kit	SLKT-233	1
Rear Inlet Seal Repair Kit	SLKT-316	1
Fitting Push-in Straight M5 - 6mm O.D. Tube	PLFT-037	1 to 2
Fitting Push-in 90° Elbow M5 - 6mm O.D. Tube	PLFT-041	1 to 2

MOUNTING ACCESSORIES

	ORDER #	QTY/UNIT
In-Line Jaw Mounting Kit	ODPL-001	1

*Sensor and cable sold separately.

See detailed option and accessory information at the end of this section.

DIRECTCONNECT™



PARALLEL GRIPPER DPL-2535 TWO JAW LONG STROKE

DPL SERIES

1.161

Specifications

	DPL-2535	
Total Rated Grip Force F @ 100 psi, 7 bar*	173 lbs.	768 N
Stroke	2.76 in	70 mm
Weight	3.97 lbs.	1.80 kg
Pressure Range (without springs)	30-100 psi	2-7 bar
Pressure Range (with springs)	60-100 psi	4-7 bar
Cylinder Bore \varnothing	0.98 in.	25 mm
Displacement	4.15 in ³	68 cm ³
Temperature Range	-4°~180° F	-20°~80° C
Actuation (open/close)	0.4/0.4 sec.	
Accuracy	±0.003 in.	±0.08 mm
Repeatability	±0.0010 in.	±0.025 mm.
Valve required to actuate single acting	3-way 2-position	
Valve required to actuate double acting	4-way, 2-position	

* With springs.

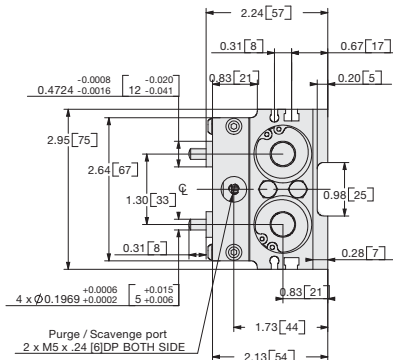
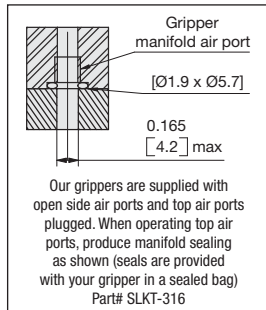
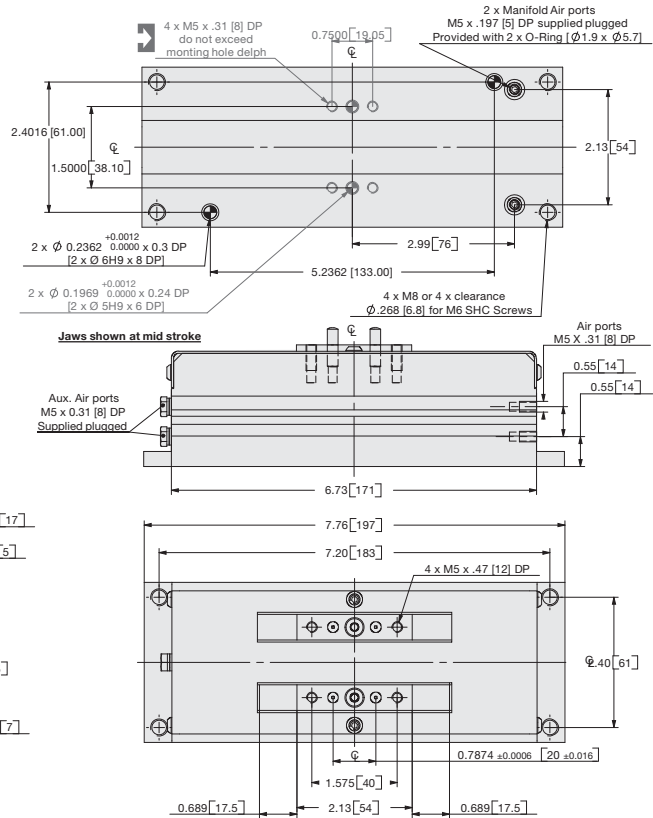

UNLESS OTHERWISE NOTED ALL TOLERANCES ARE AS SHOWN BELOW



Loading Information

How to Order: (Order Accessories separately from Basic Model)

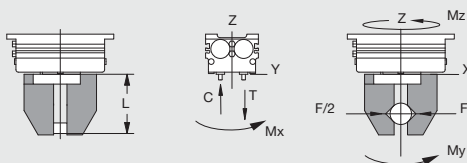
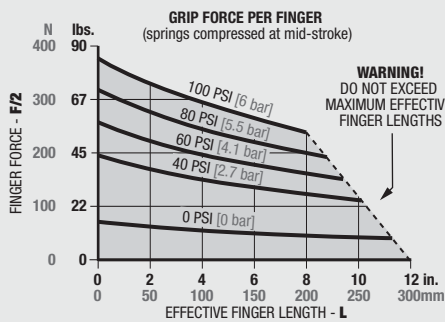

Loading Capacity [†]	Static		Dynamic	
	Imperial	Metric	Imperial	Metric
Maximum Tensile T	324 lbs.	1440 N	34 lbs.	150 N
Maximum Compressive C	411 lbs.	1380 N	34 lbs.	150 N
Maximum Moment M_x	513 in.-lbs.	58 Nm	35 in.-lbs.	4 Nm
Maximum Moment M_y	1947 in.-lbs.	220 Nm	142 in.-lbs.	16 Nm
Maximum Moment M_z	1151 in.-lbs.	130 Nm	142 in.-lbs.	16 Nm

[†]Capacities are per set of jaws and are not simultaneous

BASIC MODEL NON-SYNCHRONOUS

DPL-2535 - R - NS
SPRING

SENSOR ACCESSORIES*

	ORDER #	QTY/UNIT
PNP Magneto Resistive Sensor Long Barrel w/Qk Disc*	OHSP-017	1 to 3
NPN Magneto Resistive Sensor Long Barrel w/Qk Disc*	OHSN-017	1 to 3
PNP Magneto Resistive Sensor 90° Barrel w/Qk Disc*	OHSP-011	1 to 3
NPN Magneto Resistive Sensor 90° Barrel w/Qk Disc*	OHSN-011	1 to 3
Inductive Sensor Mounting Kit (3 Holders + 2 Flags)	OSMK-099	1
M8 NPN Inductive Sensor with Quick Disconnect*	OISP-011	1 to 3
M8 NPN Inductive Sensor with Quick Disconnect*	OISN-011	1 to 3
Quick Disconnect 2 Meter Cable Length*	CABL-010	1 to 3
Quick Disconnect 5 Meter Cable Length*	CABL-013	1 to 3

PNEUMATIC ACCESSORIES

	ORDER #	QTY/UNIT
Standard Seal Repair Kit	SLKT-233	1
Rear Inlet Seal Repair Kit	SLKT-316	1
Fitting Push-in Straight M5 - 6mm O.D. Tube	PLFT-037	1 to 2
Fitting Push-in 90° Elbow M5 - 6mm O.D. Tube	PLFT-041	1 to 2

MOUNTING ACCESSORIES

	ORDER #	QTY/UNIT
In-Line Jaw Mounting Kit	ODPL-002	1

*Sensor and cable sold separately.

See detailed option and accessory information at the end of this section.

DIRECTCONNECT[™]



PARALLEL GRIPPER DPL-3230 TWO JAW LONG STROKE

DPL SERIES

1.162

Specifications

	DPL-3230	
Total Rated Grip Force F @ 100 psi, 7 bar*	306 lbs.	1359 N
Stroke	2.36 in	60 mm
Weight	4.98 lbs.	2.26 kg
Pressure Range (without springs)	30-100 psi	2-7 bar
Pressure Range (with springs)	60-100 psi	4-7 bar
Cylinder Bore \varnothing	1.26 in.	32 mm
Displacement	5.86 in ³	96 cm ³
Temperature Range	-4°~180° F	-20°~80° C
Actuation (open/close)	0.4/0.4 sec.	
Accuracy	±0.003 in.	±0.08 mm
Repeatability	±0.0010 in.	±0.025 mm.
Valve required to actuate single acting	3-way 2-position	
Valve required to actuate double acting	4-way, 2-position	

* With springs.

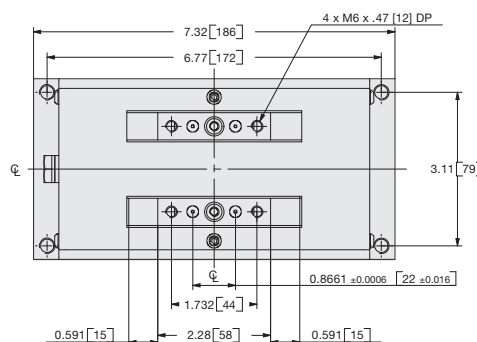
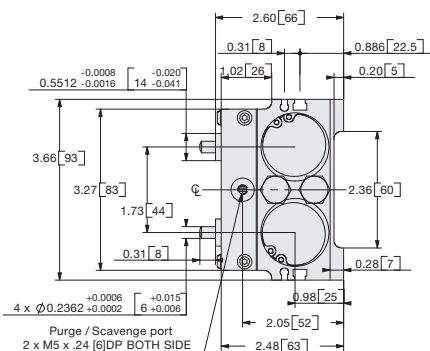
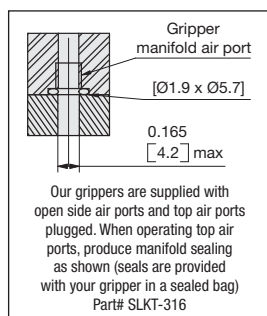
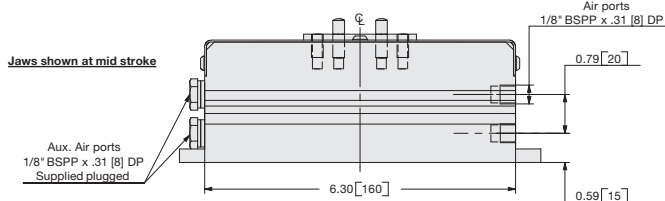
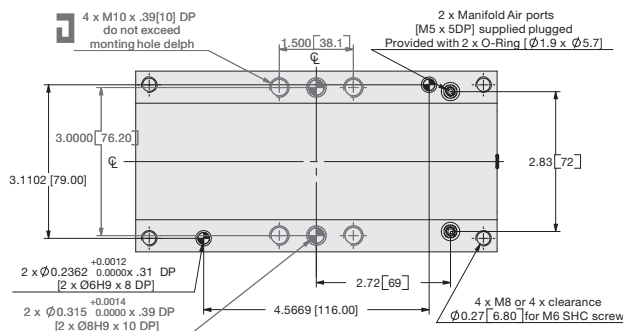

UNLESS OTHERWISE NOTED ALL TOLERANCES ARE AS SHOWN BELOW



Dimensions are symmetrical about centerline



Third Angle Projection



All Dowel Holes are SF (Slip Fit). Locational Tolerance ±.0005" or [±.013mm]



Metric Threads Course Pitch

Loading Information

How to Order: (Order Accessories separately from Basic Model)

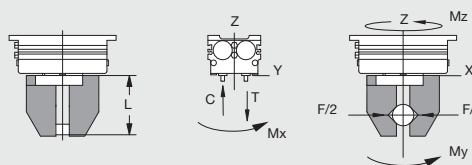
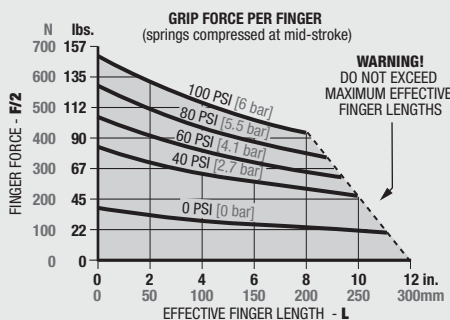

Loading Capacity [†]	Static		Dynamic	
	Imperial	Metric	Imperial	Metric
Maximum Tensile T	343 lbs.	1525 N	61 lbs.	270 N
Maximum Compressive C	427 lbs.	1900 N	61 lbs.	270 N
Maximum Moment M_x	673 in.-lbs.	76 Nm	71 in.-lbs.	8 Nm
Maximum Moment M_y	2009 in.-lbs.	227 Nm	195 in.-lbs.	22 Nm
Maximum Moment M_z	1062 in.-lbs.	120 Nm	195 in.-lbs.	22 Nm

[†]Capacities are per set of jaws and are not simultaneous

BASIC MODEL

NON-SYNCHRONOUS

DPL-3230 - **R** - **NS**

SPRING

SENSOR ACCESSORIES*

	ORDER #	QTY/UNIT
PNP Magneto Resistive Sensor Long Barrel w/Qk Disc*	OHSP-017	1 to 3
NPN Magneto Resistive Sensor Long Barrel w/Qk Disc*	OHSN-017	1 to 3
PNP Magneto Resistive Sensor 90° Barrel w/Qk Disc*	OHSP-011	1 to 3
NPN Magneto Resistive Sensor 90° Barrel w/Qk Disc*	OHSN-011	1 to 3
Inductive Sensor Mounting Kit (3 Holders + 2 Flags)	OSMK-100	1
M8 PNP Inductive Sensor with Quick Disconnect*	OISP-011	1 to 3
M8 NPN Inductive Sensor with Quick Disconnect*	OISN-011	1 to 3
Quick Disconnect 2 Meter Cable Length*	CABL-010	1 to 3
Quick Disconnect 5 Meter Cable Length*	CABL-013	1 to 3

PNEUMATIC ACCESSORIES

	ORDER #	QTY/UNIT
Standard Seal Repair Kit	SLKT-234	1
Rear Inlet Seal Repair Kit	SLKT-316	1
Fitting Push-in Straight G1/8 - 6mm O.D. Tube	PLFT-038	1 to 2
Fitting Push-in 90° Elbow G1/8 - 6mm O.D. Tube	PLFT-042	1 to 2

MOUNTING ACCESSORIES

	ORDER #	QTY/UNIT
In-Line Jaw Mounting Kit	ODPL-003	1

*Sensor and cable sold separately.

See detailed option and accessory information at the end of this section.

DIRECTCONNECT

Specifications

		DPL-3250	
Total Rated Grip Force F @ 100 psi, 7 bar*	294 lbs.	1306 N	
Stroke	3.94 in	100 mm	
Weight	6.66 lbs.	3.02 kg	
Pressure Range (without springs)	30-100 psi	2-7 bar	
Pressure Range (with springs)	60-100 psi	4-7 bar	
Cylinder Bore \varnothing	1.26 in.	32 mm	
Displacement	9.96 in ³	160 cm ³	
Temperature Range	-4°~180° F	-20°~80° C	
Actuation (open/close)		0.5/0.5 sec.	
Accuracy	±0.003 in.	±0.08 mm	
Repeatability	±0.0010 in.	±0.025 mm.	
Valve required to actuate single acting		3-way 2-position	
Valve required to actuate double acting		4-way, 2-position	

* With springs.

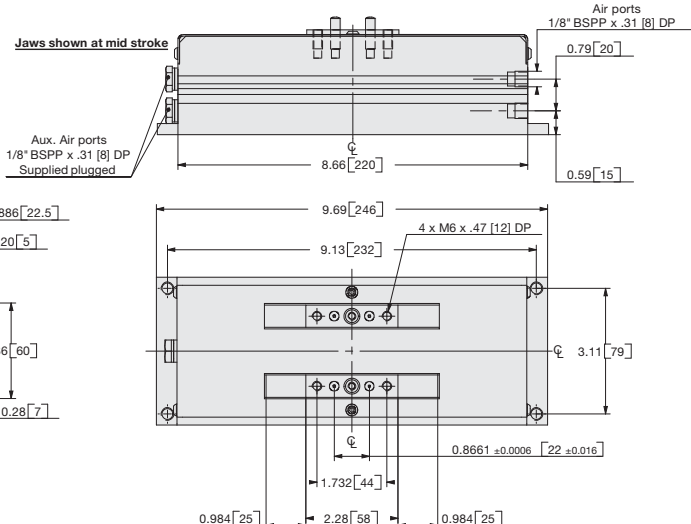
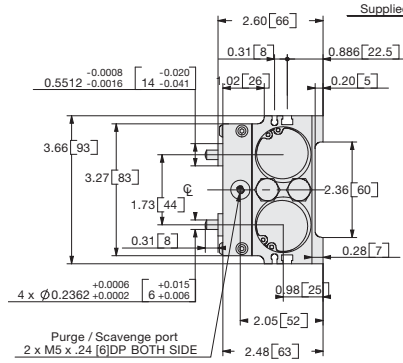
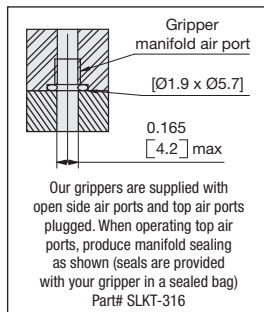
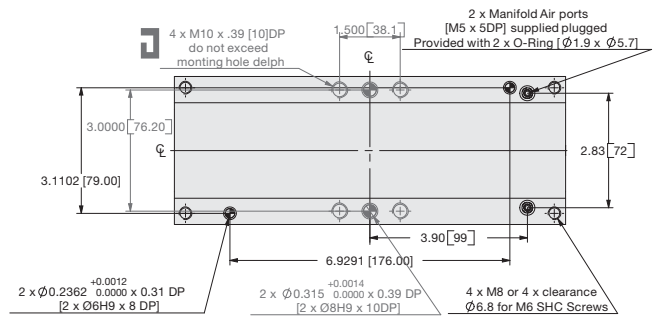

UNLESS OTHERWISE NOTED ALL TOLERANCES ARE AS SHOWN BELOW



Dimensions are symmetrical about centerline



Third Angle Projection



All Dowel Holes are SF (Slip Fit). Locational Tolerance ±.0005" or [±.013mm]



Metric Threads Course Pitch

Loading Information

How to Order: (Order Accessories separately from Basic Model)

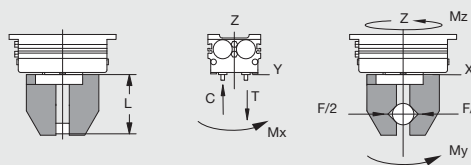
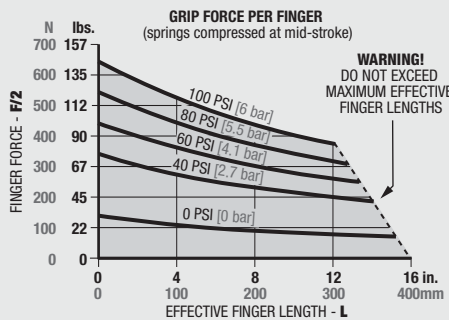

Loading Capacity [†]	Static		Dynamic	
	Imperial	Metric	Imperial	Metric
Maximum Tensile T	416 lbs.	1850 N	58 lbs.	260 N
Maximum Compressive C	520 lbs.	2315 N	58 lbs.	260 N
Maximum Moment M_x	770 in.-lbs.	87 Nm	71 in.-lbs.	8 Nm
Maximum Moment M_y	3098 in.-lbs.	350 Nm	283 in.-lbs.	32 Nm
Maximum Moment M_z	1682 in.-lbs.	190 Nm	283 in.-lbs.	32 Nm

[†]Capacities are per set of jaws and are not simultaneous

BASIC MODEL

NON-SYNCHRONOUS

DPL-3250 - **R** - **NS**

SPRING

SENSOR ACCESSORIES*

	ORDER #	QTY/UNIT
PNP Magneto Resistive Sensor Long Barrel w/Qk Disc*	OHSP-017	1 to 3
NPN Magneto Resistive Sensor Long Barrel w/Qk Disc*	OHSN-017	1 to 3
PNP Magneto Resistive Sensor 90° Barrel w/Qk Disc*	OHSP-011	1 to 3
NPN Magneto Resistive Sensor 90° Barrel w/Qk Disc*	OHSN-011	1 to 3
Inductive Sensor Mounting Kit (3 Holders + 2 Flags)	OSMK-100	1
M8 PNP Inductive Sensor with Quick Disconnect*	OISP-011	1 to 3
M8 NPN Inductive Sensor with Quick Disconnect*	OISN-011	1 to 3
Quick Disconnect 2 Meter Cable Length*	CABL-010	1 to 3
Quick Disconnect 5 Meter Cable Length*	CABL-013	1 to 3

PNEUMATIC ACCESSORIES

Standard Seal Repair Kit	SLKT-234	1
Rear Inlet Seal Repair Kit	SLKT-316	1
Fitting Push-in Straight 1/8 - 6mm O.D. Tube	PLFT-038	1 to 2
Fitting Push-in 90° Elbow 1/8 - 6mm O.D. Tube	PLFT-042	1 to 2

MOUNTING ACCESSORIES

In-Line Jaw Mounting Kit	ODPL-004	1
--------------------------	-----------------	----------

*Sensor and cable sold separately.

See detailed option and accessory information at the end of this section



PARALLEL GRIPPER DPL-4040 TWO JAW LONG STROKE

DPL SERIES

1.164

Specifications

	DPL-4040	
Total Rated Grip Force F @ 100 psi, 7 bar*	457 lbs.	2035 N
Stroke	3.15 in.	80 mm
Weight	9.48 lbs.	4.30 kg
Pressure Range (without springs)	30-100 psi	2-7 bar
Pressure Range (with springs)	60-100 psi	4-7 bar
Cylinder Bore \varnothing	1.57 in.	40 mm
Displacement	12.20 in ³	200 cm ³
Temperature Range	-4°~180° F	-20°~80° C
Actuation (open/close)	0.5/0.5 sec.	
Accuracy	±0.003 in.	±0.08 mm
Repeatability	±0.0010 in.	±0.025 mm.
Valve required to actuate single acting	3-way 2-position	
Valve required to actuate double acting	4-way, 2-position	

* With springs.

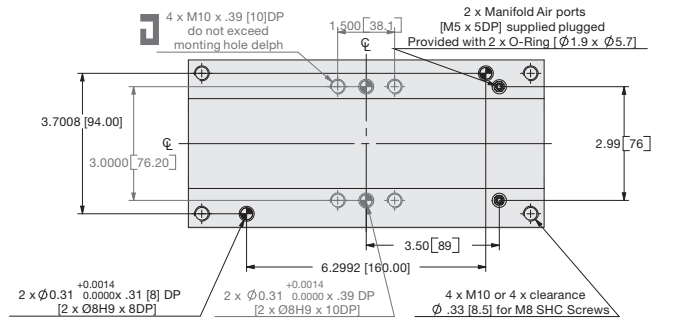

Jaws shown at mid stroke

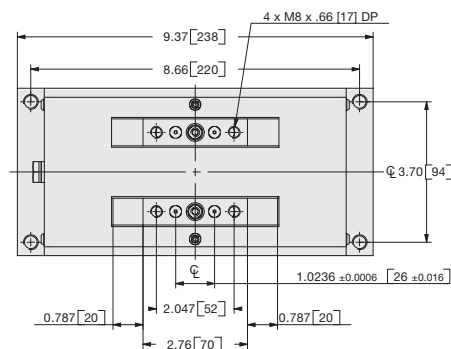
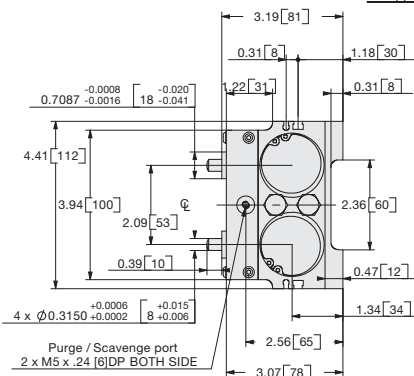
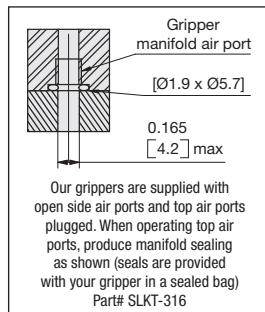
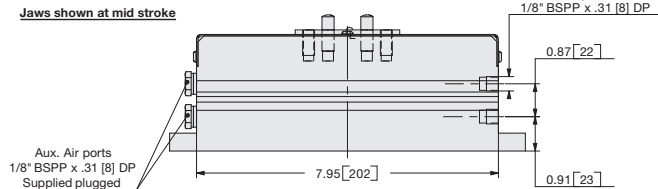

UNLESS OTHERWISE NOTED ALL TOLERANCES ARE AS SHOWN BELOW

- Dimensions are symmetrical about centerline
- Third Angle Projection
- All Dowel Holes are SF (Slip Fit). Locational Tolerance ±.0005" or (±.013mm)
- Metric Threads Course Pitch

Loading Information

How to Order: (Order Accessories separately from Basic Model)

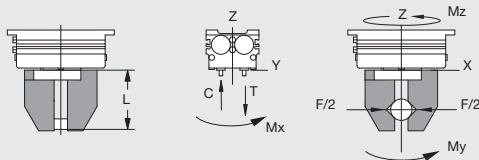
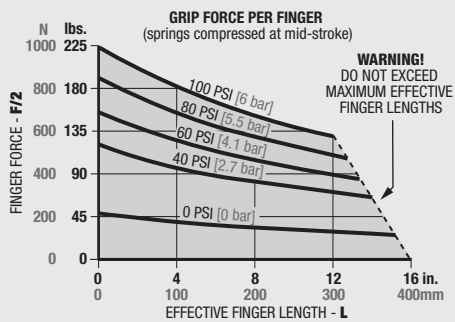

Loading Capacity [†]	Static		Dynamic	
	Imperial	Metric	Imperial	Metric
Maximum Tensile T	456 lbs.	2030 N	90 lbs.	400 N
Maximum Compressive C	549 lbs.	2440 N	90 lbs.	400 N
Maximum Moment M_x	1195 in.-lbs.	135 Nm	124 in.-lbs.	14 Nm
Maximum Moment M_y	3717 in.-lbs.	420 Nm	381 in.-lbs.	43 Nm
Maximum Moment M_z	1947 in.-lbs.	220 Nm	381 in.-lbs.	43 Nm

[†]Capacities are per set of jaws and are not simultaneous

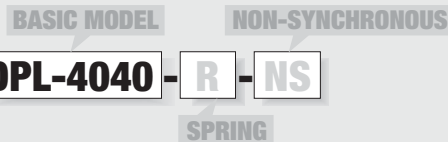

SENSOR ACCESSORIES*

	ORDER #	QTY/UNIT
M8 PNP Magneto Resistive Sensor Long Barrel w/Qk Disc*	OHSP-017	1 to 3
M8 NPN Magneto Resistive Sensor Long Barrel w/Qk Disc*	OHSN-017	1 to 3
M8 PNP Magneto Resistive Sensor 90° Barrel w/Qk Disc*	OHSP-011	1 to 3
M8 NPN Magneto Resistive Sensor 90° Barrel w/Qk Disc*	OHSN-011	1 to 3
Inductive Sensor Mounting Kit (3 Holders + 2 Flags)	OSMK-101	1
M12 PNP Inductive Sensor with Quick Disconnect*	OISP-017	1 to 3
M12 NPN Inductive Sensor with Quick Disconnect*	OISN-017	1 to 3
M8 Quick Disconnect 2 Meter Cable Length*	CABL-010	1 to 3
M8 Quick Disconnect 5 Meter Cable Length*	CABL-013	1 to 3
M12 Quick Disconnect 2 Meter Cable Length*	CABL-014	1 to 3
M12 Quick Disconnect 5 Meter Cable Length*	CABL-018	1 to 3

PNEUMATIC ACCESSORIES

Standard Seal Repair Kit	SLKT-235	1
Rear Inlet Seal Repair Kit	SLKT-316	1
Fitting Push-in Straight G1/8 - 6mm O.D. Tube	PLFT-038	1 to 2
Fitting Push-in 90° Elbow G1/8 - 6mm O.D. Tube	PLFT-042	1 to 2

MOUNTING ACCESSORIES

In-Line Jaw Mounting Kit	ODPL-005	1
--------------------------	-----------------	----------

*Sensor and cable sold separately.

See detailed option and accessory information at the end of this section

DIRECTCONNECT



PARALLEL GRIPPER DPL-4070 TWO JAW LONG STROKE

DPL SERIES

1.165

Specifications

	DPL-4070	
Total Rated Grip Force F @ 100 psi, 7 bar*	456 lbs.	2029 N
Stroke	5.51 in	140 mm
Weight	13.23 lbs.	6.00 kg
Pressure Range (without springs)	30-100 psi	2-7 bar
Pressure Range (with springs)	60-100 psi	4-7 bar
Cylinder Bore \varnothing	1.57 in.	40 mm
Displacement	21.36 in ³	350 cm ³
Temperature Range	-4°~180° F	-20°~80° C
Actuation (open/close)	0.7/0.7 sec.	
Accuracy	±0.003 in.	±0.08 mm
Repeatability	±0.0010 in.	±0.025 mm.
Valve required to actuate single acting	3-way 2-position	
Valve required to actuate double acting	4-way, 2-position	

* With springs.

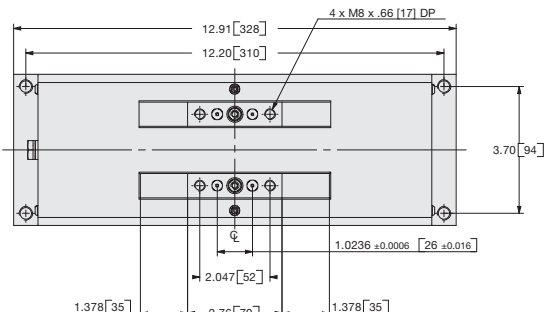
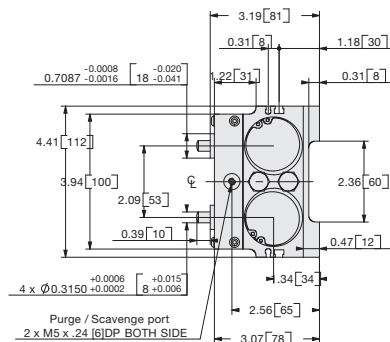
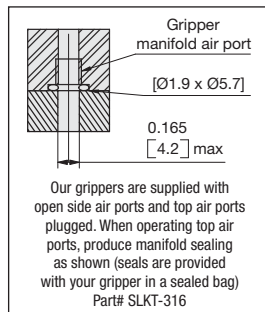
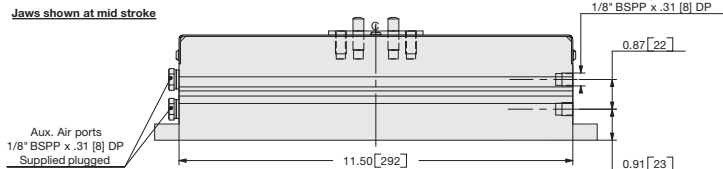
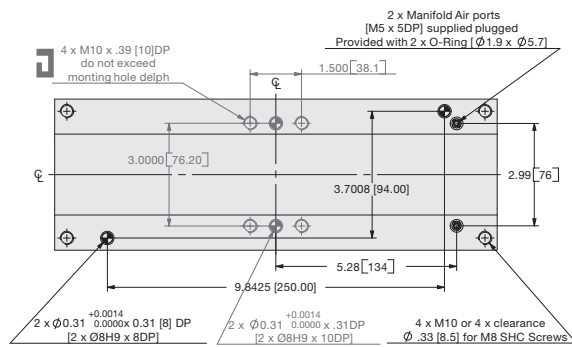

UNLESS OTHERWISE NOTED ALL TOLERANCES ARE AS SHOWN BELOW



Dimensions are symmetrical about centerline



Third Angle Projection



All Dowel Holes are SF (Slip Fit).
Locational Tolerance ±.0005" or [±.013mm]



Metric Threads
Course Pitch

Loading Information

How to Order: (Order Accessories separately from Basic Model)

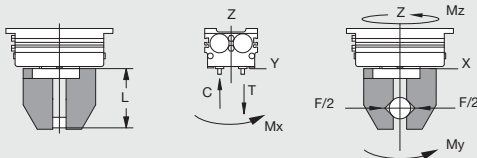
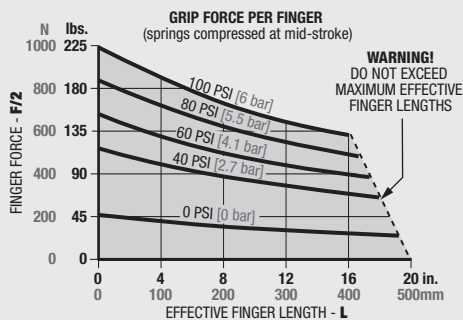

Loading Capacity [†]	Static		Dynamic	
	Imperial	Metric	Imperial	Metric
Maximum Tensile T	564 lbs.	2510 N	90 lbs.	400 N
Maximum Compressive C	677 lbs.	3010 N	90 lbs.	400 N
Maximum Moment M_x	1416 in.-lbs.	160 Nm	133 in.-lbs.	15 Nm
Maximum Moment M_y	5885 in.-lbs.	665 Nm	566 in.-lbs.	64 Nm
Maximum Moment M_z	3098 in.-lbs.	350 Nm	566 in.-lbs.	64 Nm

[†]Capacities are per set of jaws and are not simultaneous

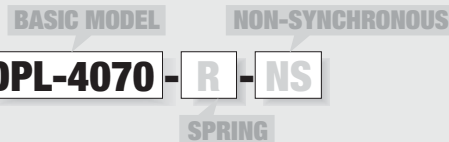

SENSOR ACCESSORIES*

	ORDER #	QTY/UNIT
M8 PNP Magneto Resistive Sensor Long Barrel w/Qk Disc*	OHSP-017	1 to 3
M8 NPN Magneto Resistive Sensor Long Barrel w/Qk Disc*	OHSN-017	1 to 3
M8 PNP Magneto Resistive Sensor 90° Barrel w/Qk Disc*	OHSP-011	1 to 3
M8 NPN Magneto Resistive Sensor 90° Barrel w/Qk Disc*	OHSN-011	1 to 3
Inductive Sensor Mounting Kit (3 Holders + 2 Flags)	OSMK-101	1
M12 PNP Inductive Sensor with Quick Disconnect*	OISP-017	1 to 3
M12 NPN Inductive Sensor with Quick Disconnect*	OISN-017	1 to 3
M8 Quick Disconnect 2 Meter Cable Length*	CABL-010	1 to 3
M8 Quick Disconnect 5 Meter Cable Length*	CABL-013	1 to 3
M12 Quick Disconnect 2 Meter Cable Length*	CABL-014	1 to 3
M12 Quick Disconnect 5 Meter Cable Length*	CABL-018	1 to 3

PNEUMATIC ACCESSORIES

Standard Seal Repair Kit	SLKT-235	1
Rear Inlet Seal Repair Kit	SLKT-316	1
Fitting Push-in Straight G1/8 - 6mm O.D. Tube	PLFT-038	1 to 2
Fitting Push-in 90° Elbow G1/8 - 6mm O.D. Tube	PLFT-042	1 to 2

MOUNTING ACCESSORIES

In-Line Jaw Mounting Kit	ODPL-006	1
--------------------------	-----------------	----------

*Sensor and cable sold separately.

See detailed option and accessory information at the end of this section.

DIRECTCONNECT™

DPL SERIES OPTIONS & ACCESSORIES

Optional Spring Assist (-R):

The safety spring allows the gripper to retain the part should the air supply fail or allows the gripper to be used in single acting mode. The **-R** option is ideal for internal (ID) or external gripping (OD). The ID or OD will depend on the finger design. The fingers will face towards center of gripper for OD gripping or will face outward for ID gripping.

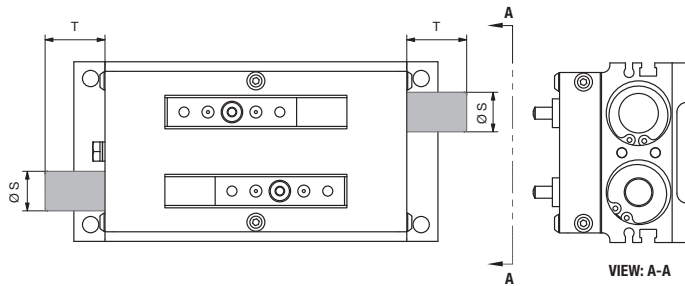

Use With	S	T
DPL-2520-R	0.65 [16.5]	0.98 [25]
DPL-2535-R	0.65 [16.5]	1.18 [30]
DPL-3230-R	0.98 [25]	0.76 [19.3]
DPL-3250-R	0.98 [25]	0.96 [24.3]
DPL-4040-R	1.10 [28]	1.69 [42.8]
DPL-4070-R	1.16 [29.5]	0.98 [24.8]

In-Line Jaw Adapter:

The In-Line Jaw Adapter allows for the simplification of the finger design. It provides for "in-line" alignment of the finger mounting holes. The kit includes 2 interfaces, screws, and dowel kit.

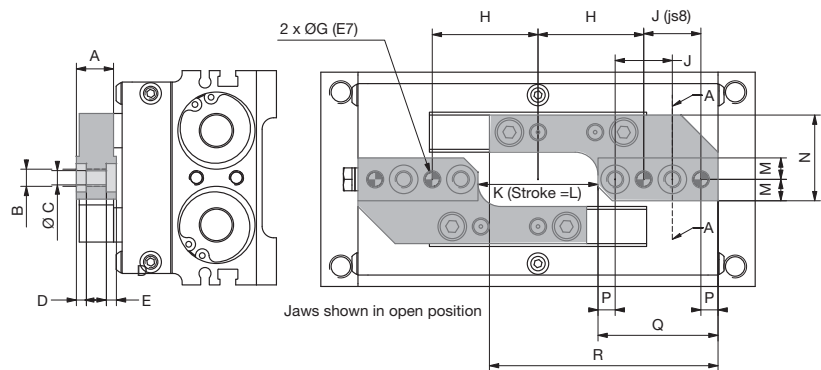

Fingers can be mounted on the accessory from the top (using SHC screws) or from the bottom (using low head SHC screws)

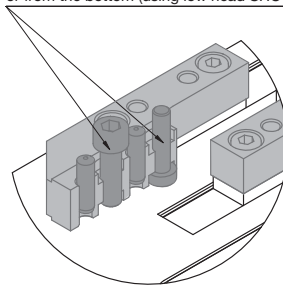

Second direction for mounting the accessory When used with the -R option, it allows to secure for internal or external clamping

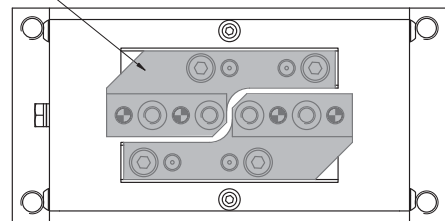

Order #	Use With	A	B	C	D	E	F	G	H	J	K	L	M	N	P	Q	R
ODPL-001	DPL-2520	0.51 [13]	M6	0.20 [5]	0.14 [3.5]	0.28 [7]	M5	0.20 [5]	1.46 [37]	0.79 [20]	1.65 [42]	1.57 [40]	0.30 [7.5]	1.18 [30]	0.24 [6]	1.65 [42]	3.15 [80]
ODPL-002	DPL-2535	0.51 [13]	M6	0.20 [5]	0.14 [3.5]	0.28 [7]	M5	0.20 [5]	2.05 [52]	0.79 [20]	2.83 [72]	2.76 [70]	0.30 [7.5]	1.18 [30]	0.24 [6]	1.65 [42]	3.44 [87.5]
ODPL-003	DPL-3230	0.59 [15]	M8	0.27 [6.8]	0.12 [3]	0.39 [10]	M6	0.24 [6]	1.97 [50]	0.87 [22]	2.44 [62]	2.36 [60]	0.39 [10]	1.54 [39]	0.31 [8]	1.93 [49]	3.70 [94]
ODPL-004	DPL-3250	0.59 [15]	M8	0.27 [6.8]	0.12 [3]	0.39 [10]	M6	0.24 [6]	2.76 [70]	0.87 [22]	4.02 [102]	3.94 [100]	0.39 [10]	1.54 [39]	0.31 [8]	1.93 [49]	4.09 [104]
ODPL-005	DPL-4040	0.83 [21]	M10	0.33 [8.5]	0.20 [5]	0.47 [12]	M8	0.31 [8]	2.48 [63]	1.02 [26]	3.23 [82]	3.15 [80]	0.47 [12]	1.87 [47.5]	0.35 [9]	2.24 [57]	4.45 [113]
ODPL-006	DPL-4070	0.83 [21]	M10	0.33 [8.5]	0.20 [5]	0.47 [12]	M8	0.31 [8]	3.66 [93]	1.02 [26]	5.59 [142]	5.51 [140]	0.47 [12]	1.87 [47.5]	0.35 [9]	2.24 [57]	5.04 [128]

Inductive Sensors Holder:

Sense up to 3 jaw positions; open jaws, closed jaws, and part present. The kit includes 3 sensor holders and 2 flags. Sensors are not included.

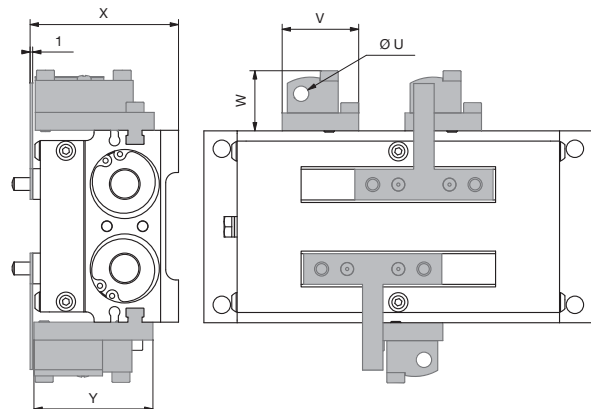

Order #	Use With	U	V	W	X	Y
OSMK-099	DPL-2520	0.31 [8]	1.18 [30]	0.95 [24]	2.28 [58]	1.83 [46.5]
	DPL-2535	0.31 [8]	1.18 [30]	0.95 [24]	2.28 [58]	1.83 [46.5]
OSMK-100	DPL-3230	0.31 [8]	0.87 [22]	0.95 [24]	2.64 [67]	1.97 [50]
	DPL-3250	0.31 [8]	0.87 [22]	0.95 [24]	2.64 [67]	1.97 [50]
OSMK-101	DPL-4040	0.47 [12]	0.87 [22]	1.06 [27]	3.23 [82]	2.26 [57.5]
	DPL-4070	0.47 [12]	0.87 [22]	1.06 [27]	3.23 [82]	2.26 [57.5]

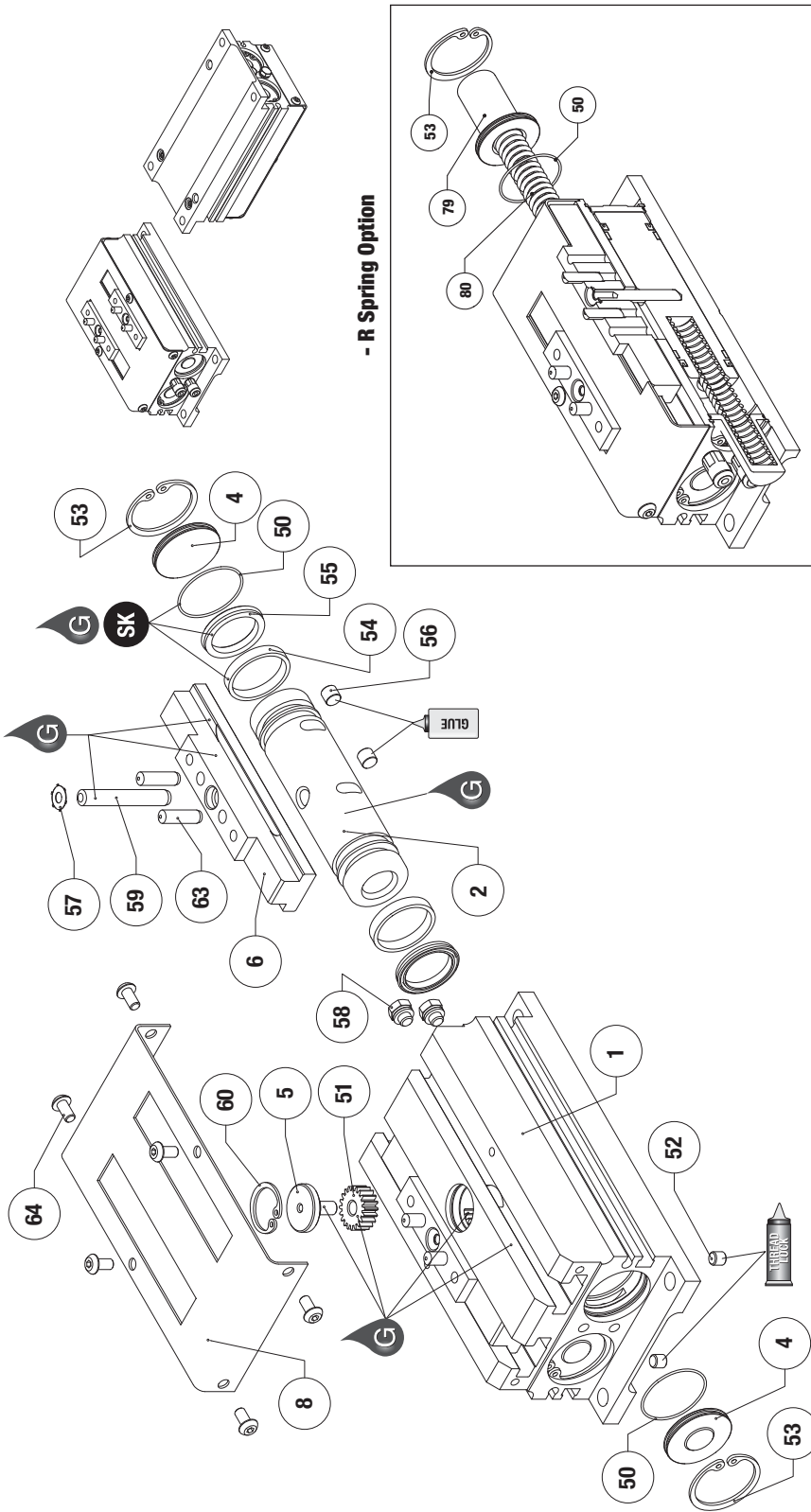

Item	Qty	Name
01	1	Body
02	2	Piston
04	4	Cap
05	1	Gear Cover
06	2	Jaw
08	1	Shielded Case
50	4	Seal, Cap
51	1	Synchronization Pinion
52	2	Set Screw-Manifold Port Plugs
53	4	Retainer Ring, Cap
54	4	Piston Ring Guidance
55	4	Piston U-Cup
56	4	Magnet
57	2	Drive Pin Retainer Ring
58	2	Manifold Port Plugs
59	2	Drive Pin
60	2	Center Retaining Ring
63	4	Jaw Dowel Pin
64	6	Shielded Case Screws
79	2	Spring Cap
80	2	Spring

NOTE: Contact the Robohand Sales Department for a complete spare parts list with order numbers and prices.

Assembly Procedure

- 1) Glue magnets #56 into the piston slots #2.
- 2) If top air ports are not used, plug the body #1 with screws #52 using glue.
- 3) Lubricate and install the U-Cup seals #55 and the guidance ring #54 onto the piston #2.
- 4) Lubricate and assemble the piston #2 into the body #1 using the adequate tooling
- 5) Press dowel pins #63 into the jaws #6.
- 6) Lubricate and install the jaws #6 into the slots #1.
- 7) Press the drive pin #59 and the retaining ring #57 through the jaws #6 and the piston #2.
- 8) Lubricate and install the axis #5, the pinion #51, the retaining ring #60 into the body. Beware of the correctly place the jaws to get a synchronous motion.
- 9) Lubricate and install the seal #50 onto the cap #4.
- 10) Install the cap #4 and the retaining ring #53 into the cap #1.
- 11) Install the shielded case #8.
- 12) Screw the plugs #58 into the body #1.

Assembly - Spring option

- 1) Lubricate and install the seal (#50) onto the cap.
- 2) Install the spring into the piston bore and into the cap bore.
- 3) Compress the spring till the cap reach its correct position on the body.
- 4) Install the retaining ring.

**SK Seal Repair Kit Order #'s
See Product Data Sheets**

Seal Kit Items	Thread Locker	Krytox™ Lubricant	Lightweight Machine Oil	Teflon™ Based Grease	Super Bonder	Third Angle Projection
----------------	---------------	-------------------	-------------------------	----------------------	--------------	------------------------

DPL SERIES ASSEMBLED VIEW

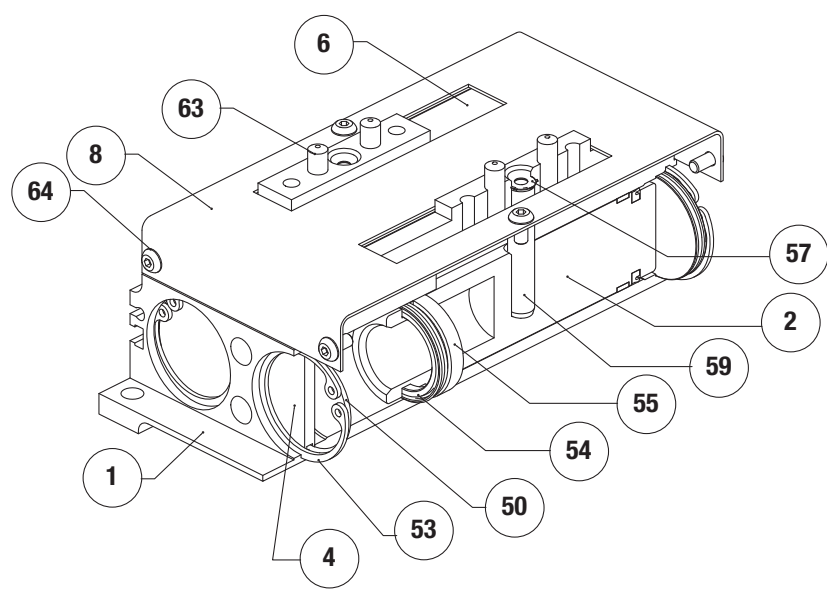

Item	Qty	Name
01	1	Body
02	2	Piston
04	4	Cap
05	1	Axis
06	2	Jaw
08	1	Shielded Case
50	4	Seal, Cap
51	1	Synchronization Pinion
52	2	Set Screw-Manifold Port Plugs
53	4	Retainer Ring, Cap
54	4	Piston Ring Guidance
55	4	Piston U-Cup
56	4	Magnet
57	2	Drive Pin Retainer Ring
58	2	Stopper-Manifold Port Plugs
59	2	Drive Pin
60	2	Center Retaining Ring
63	4	Jaw Dowel Pin
64	6	Shielded Case Screws

NOTE: Contact the Robohand Sales Department for a complete spare parts list with order numbers and prices.

ACCESSORY INSTALLATION & ADJUSTMENT INSTRUCTIONS

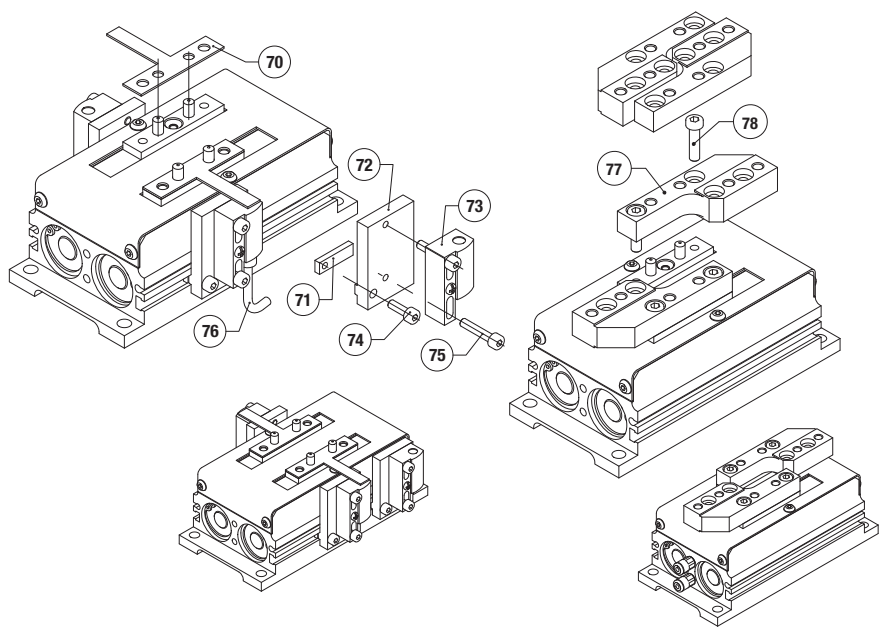

Installation - Inductive Sensors Holder Kit

- 1) Place the flags (#2) on the jaws as shown.
- 2) Install the sensor holder (#72) on the adapter (#73) using the screws (#75)
- 3) Tighten the sensor (not shown) into the sensor holder(#73).
- 4) Install the nut (#71) into the slot of the body and the adapter (#72) on the slot. Install the screw (#74) to fix the adapter on the nut.
- 5) Loosen the screw (#74) and slide the assembly until the light indicates.
- 6) Tighten the screw (#74).

Installation - In-Line Jaws

- 1) Install the interface (#77) onto the jaws. When combined with the **-R** option and according to the mounting direction, the interface can be used for internal or external clamping.
- 2) Tighten the screw (#78) between the interface (#77) and the jaw.

Seal Kit Items	Thread Locker	Krytox™ Lubricant	Lightweight Machine Oil	Teflon™ Based Grease	Super Bonder	Third Angle Projection



DESIGN NOTES

DPL SERIES

1.169

