

Angular Grippers - 180° Spring Assist Series

DCT-RE/CT-RE
SERIES

2.44

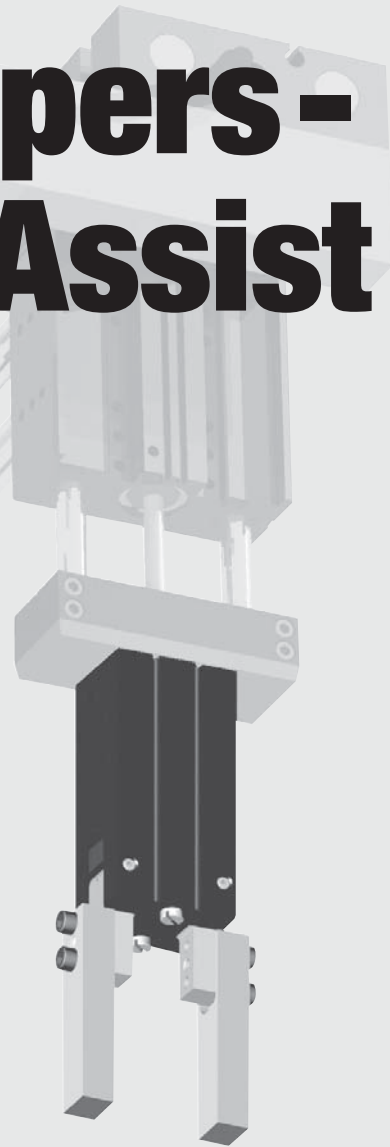

- 180° angular gripper:**
 The full jaw opening (180°) means that the part can be direct fed, avoiding any release movement by the robot or by the actuator.
- Multiple mounting locations:**
 DIRECTCONNECT™ mounting on back of body (sizes 12-25). Standard mounting on top.
- Fail safe operation:**
 The force supplied from the internal spring can be used to maintain gripping force if the gripper loses air pressure.
- Compact gripper:**
 This gripper is designed for use in confined spaces.
- Multipurpose gripper:**
 Several accessories (adjustable stop, magneto resistive or inductive sensors) allow this gripper to be used in a number of applications.
- Harsh environments:**
 Shielded design repels chips and other particulate from internal drive mechanism.

Mounting Information:

Gripper can be mounted and operated in any orientation

Gripper is located from the top with 2 dowel pins and assembled with 2 screws.

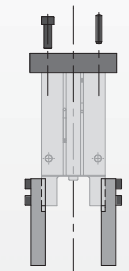

DIRECTCONNECT mounting pattern: Gripper is located with 2 dowel pins and assembled with 4 screws.

Alternative pattern: Gripper is located with 2 dowel pins and assembled with 2 screws.

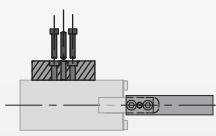

Fingers are centered over the jaws, located with 1 dowel pin and assembled with 2 screws.



The gripper is protected from falling debris when it is mounted and operated upside down.

Gripper can be operated utilizing top manifold air ports.

Technical Specifications:

Pneumatic Specifications	Imperial	Metric
Pressure Operating Range	60-100 psi	4-7 bar
Cylinder Type	Double Acting Spring Assist or Single Acting Spring Return	
Dynamic Seals	Internally Lubricated Buna-N	
Valve Required to Operate	4-way, 2-position	
Air Quality Requirements	40 Micron or Better	
Air Filtration	Not Necessary*	
Air Lubrication	Low Moisture Content (dry)	
Air Humidity		
Temperature Operating Range		
Buna-N Seals (Standard)	-30°~180° F	-35°~80° C
Viton® Seals (Optional)	-20°~300° F	-30°~150° C

Maintenance Specifications†

Expected Life	5 million cycles
Normal Application w/ Preventative Maintenance	10+ million cycles*
Field Repairable	Yes
Seal Repair Kits Available	Yes

*Addition of lubrication will greatly increase service life
 † See Maintenance Section

DIRECTCONNECT™

Product Features

Gripper Attachment

Gripper mounting from side or bottom

Viton Seals

Viton seals for high temperatures (-20°F to +300°F / -30°C to +150°C) are optional

Quality Components

Made from aluminum alloy anodized with Teflon™ impregnation. The gripper's main components are made of heat treated steel.

Inductive Sensor Mounting Kit

Accessory (SD) in order to control jaw position: comes with 2 holders for tubular sensors and 2 adjustable flags (except size -12)

Magneto Resistive Sensor Mounting Kit

The gripper comes with adjustable slots for the 2 magnetic sensors (to control jaw position)

Adjustable Stop

Accessory (BR) in order to adjust the opening of jaws, between 0° to 180°

Shielded Plate and Wiper Covers

Gripper body is shielded to repel chips and other particulate from internal drive mechanism

DIRECTCONNECT Mounting Patterns

DIRECTCONNECT™ mounting surface on back of body (sizes 12-25)

Fail Safe Spring

Internal spring allows the gripper to hold onto part with loss of air pressure

Multiple Air Ports

Side or top air ports (top ports require 0-ring)

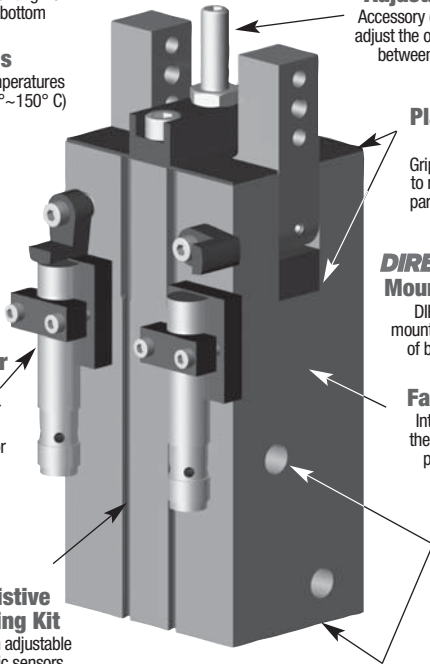

Operating Principle

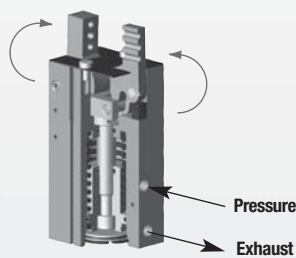
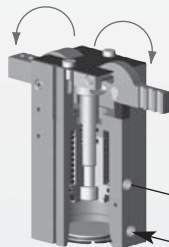
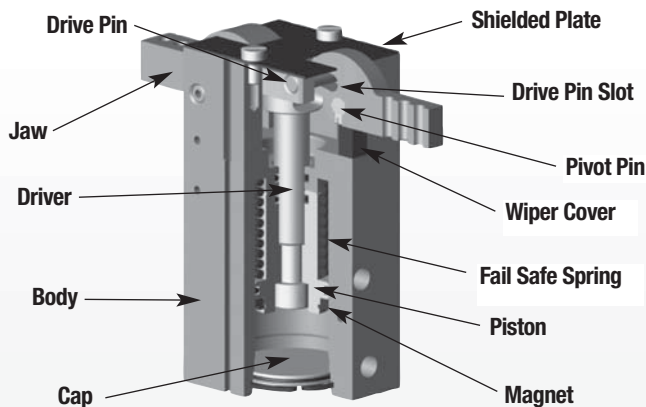

- A double acting piston, with a ring magnet for magneto resistive sensing, is connected to a fork driver on which 2 drive pins are fixed.
- Jaw rotation is synchronized with the drive pin-jaw assembly.
- Sliding in these slots, drive pins convert vertical motion of the piston into rotating opposite synchronous motion of both jaws.
- Each jaw has a useful rotation stroke of 90°, between the 90° open position and the 0° gripping position, plus a gripping over-stroke of approximately 1.5° before reaching the fully gripped position. Jaws have to be designed for a 0° gripping position (parallel jaws)
- The fail safe spring allow the gripper to retain the component should the air supply fail or for the gripper to be used in single acting mode.

Style -DCT-RE Angular Gripper

Size -12M

Style: DCT-12M-RE
Stroke: 90° each finger
Grip Force: 9 lbs 40 N
Weight: 0.26 lbs 0.12 Kg



See Page **2.46**

Style -DCT-RE Angular Gripper

Size -16M

Style: DCT-16M-RE
Stroke: 90° each finger
Grip Force: 19 lbs 87 N
Weight: 0.44 lbs 0.20 Kg



See Page **2.47**

Style -DCT-RE Angular Gripper

Size -20M

Style: DCT-20M-RE
Stroke: 90° each finger
Grip Force: 32 lbs 141 N
Weight: 0.73 lbs 0.33 Kg



See Page **2.48**

Style -DCT-RE Angular Gripper

Size -25M

Style: DCT-25M-RE
Stroke: 90° each finger
Grip Force: 45 lbs 199 Nm
Weight: 1.26 lbs 0.57 Kg



See Page **2.49**

Style -CT-RE Angular Gripper

Size -32M

Style: CT-32M-RE
Stroke: 90° each finger
Grip Force: 79 lbs 353 N
Weight: 1.83 lbs 0.83 Kg



See Page **2.50**

Style -CT-RE Angular Gripper

Size -40M

Style: CT-40M-RE
Stroke: 90° each finger
Grip Force: 133 lbs 592 N
Weight: 3.06 lbs 1.39 Kg



See Page **2.51**

Style -CT-RE Angular Gripper

Size -50M

Style: CT-50M-RE
Stroke: 90° each finger
Grip Force: 201 in-lbs 893 N
Weight: 4.87 lbs 2.21 Kg



See Page **2.52**

DCT-RE/CT-RE SERIES

2.45



DIRECTCONNECT™

ANGULAR GRIPPER DCT-12M-RE 180° SERIES



DCT-RE SERIES

2.46

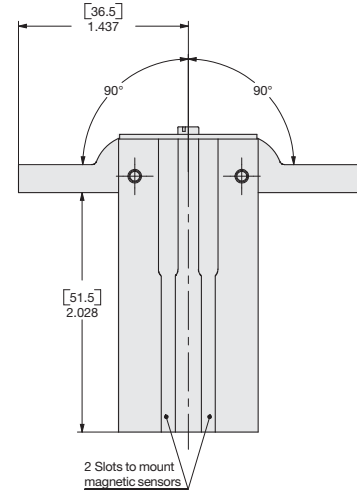
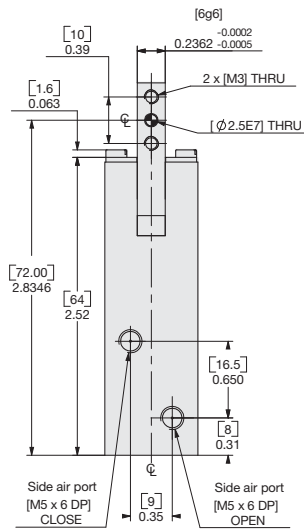
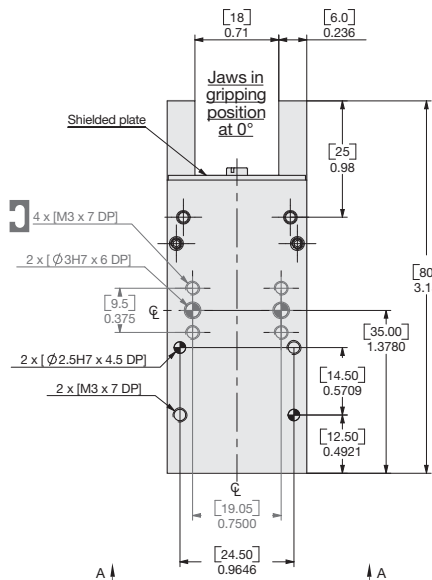

Specifications

DCT-12M-RE

Total Rated Grip Force, F @ 100 psi [7 bar]	9 lbs.	40 N
L = 1 in. [25mm] @ 0°		
Stroke	90° of stroke for each finger	
Weight	0.26 lbs.	0.12 Kg
Pressure Range	60-100 psi	4-7 Bar
Cylinder Bore Ø	0.472 in.	12 mm
Displacement	0.117 in ³	1.92 cm ³
Temperature Range		
Standard Seals	-30°~180° F	-35°~80° C
Viton® Seals	-20°~300° F	-30°~150° C
Actuation (open/close)	0.08 / 0.05 sec.	
Accuracy	±0.0028 in.	±0.07 mm
Repeatability	±0.002 in.	±0.05 mm
Valve required to actuate single acting	3-way, 2-position	
Valve required to actuate double acting	4-way, 2-position	

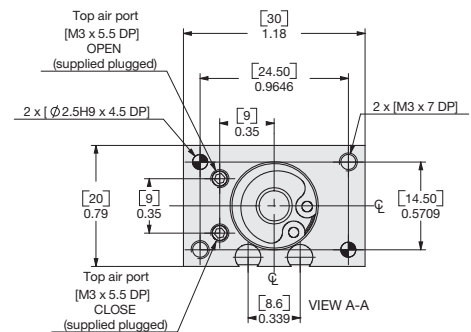
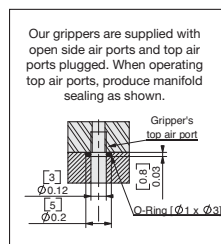

UNLESS OTHERWISE NOTED ALL TOLERANCES ARE AS SHOWN BELOW

Dimensions are symmetrical about centerline	Third Angle Projection	All Dowel Holes are SF (Slip Fit). Locational Tolerance ±.0005" or [±.013mm]	Metric Threads Course Pitch	Imperial in. 0.00 = ±.01 0.000 = ±.005 0.0000 = ±.0005	Metric [mm] [0.] = [±.25] [0.0] = [±.13] [0.00] = [±.013]
---	------------------------	--	-----------------------------	--	---

NOTE: Jaws have to be designed for a 0° gripping position (parallel jaws). Jaws will close 1.5° past parallel. To limit shocks at the end of an opening or closing stroke, it is highly recommended to design jaws with minimal inertia (as light and short as possible). Flow Controls make it possible to reduce the rotation speed and are highly recommended.

Loading Information

How to Order: (Order Accessories separately from Basic Model)

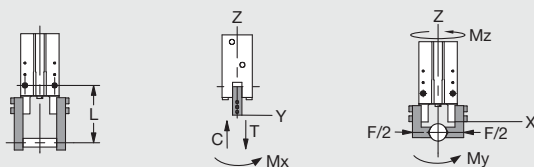
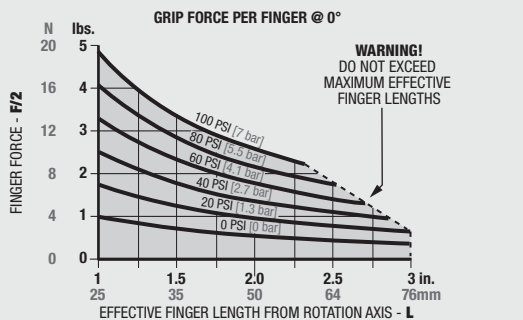

Loading Capacity [†]	Static		Dynamic	
	Imperial	Metric	Imperial	Metric
Maximum Tensile T	11 lbs.	47 N	2 lbs.	9.4 N
Maximum Compressive C	11 lbs.	47 N	2 lbs.	9.4 N
Maximum Moment M_x	10 in.-lbs.	1.1 Nm	3 in.-lbs.	1.1 Nm
Maximum Moment M_y	10 in.-lbs.	1.1 Nm	3 in.-lbs.	1.1 Nm
Maximum Moment M_z	10 in.-lbs.	1.1 Nm	3 in.-lbs.	1.1 Nm

[†]Capacities are per set of jaws and are not simultaneous

BASIC MODEL VITON® SEALS

DCT-12M-RE-V
SIZE SPRING

NOTE: DCT-12-RE can be used as an exact replacement for CT-12-RE

SENSOR ACCESSORIES*

	ORDER #	QTY/UNIT
PNP Magneto Resistive Sensor Short Barrel w/Qk Disc*	OHSP-017	1 or 2
NPN Magneto Resistive Sensor Short Barrel w/Qk Disc*	OHSN-017	1 or 2
Quick Disconnect 2 Meter Cable Length*	CABL-010	1 or 2
Quick Disconnect 5 Meter Cable Length*	CABL-013	1 or 2

PNEUMATIC ACCESSORIES

Adj. Flow Control M5 Elbow - 6mm OD Push-in (Metric)	VLVF-008	1 or 2
Buna-N Seal Repair Kit	SLKT-159	1
Viton® Seal Repair Kit	SLKT-159V	1

MOUNTING ACCESSORIES

Adjustment Stop Kit (1 Shielded Plate + 1 Stop)	KP-DCT12-BR	1
---	--------------------	----------

*Sensor and cable sold separately.

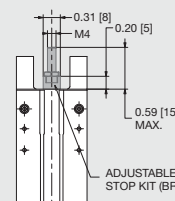

DIRECTCONNECT™

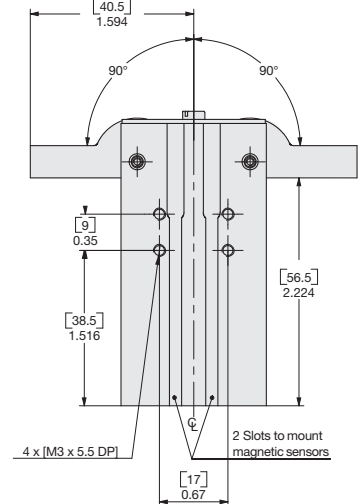
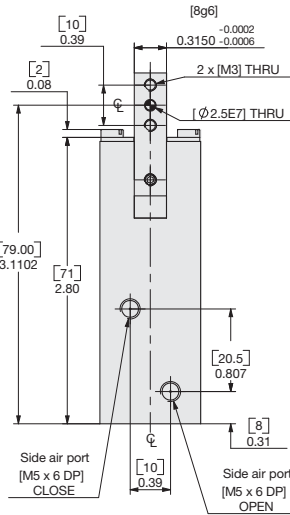
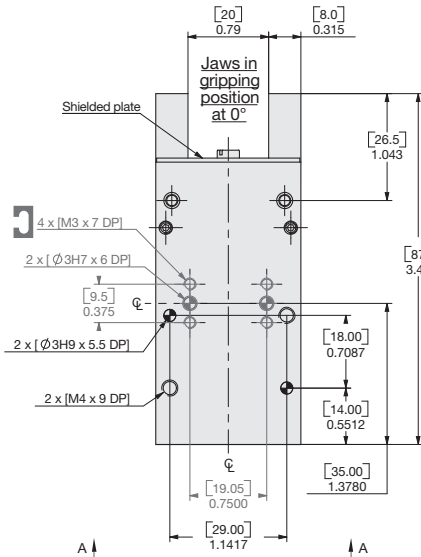

Specifications

	DCT-16M-RE	
Total Rated Grip Force, F @ 100 psi [7 bar]	19 lbs.	87 N
L = 1 in. [25mm] @ 0°	90° of stroke for each finger	
Stroke	0.44 lbs.	0.20 Kg
Weight	60-100 psi	4-7 Bar
Pressure Range	0.630 in.	16 mm
Cylinder Bore Ø	0.251 in ³	4.12 cm ³
Displacement	Temperature Range	
Temperature Range	Standard Seals	-30°~180° F -35°~80° C
Standard Seals	Viton® Seals	-20°~300° F -30°~150° C
Viton® Seals	Actuation (open/close)	0.15 / 0.12 sec.
Actuation (open/close)	Accuracy	±0.0028 in. ±0.07 mm
Accuracy	Repeatability	±0.002 in. ±0.05 mm.
Repeatability	Valve required to actuate single acting	3-way, 2-position
Valve required to actuate single acting	Valve required to actuate double acting	4-way, 2-position

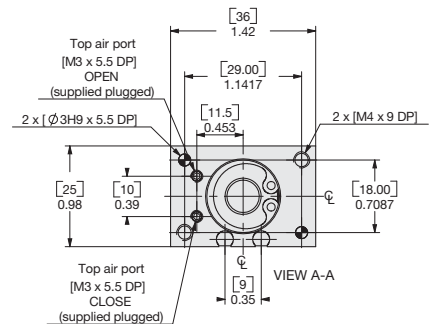
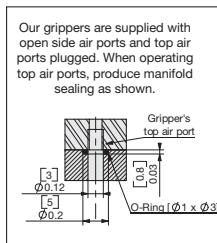

UNLESS OTHERWISE NOTED ALL TOLERANCES ARE AS SHOWN BELOW

Symbol	Imperial in.	Metric [mm]
Dimensions are symmetrical about centerline	0.00 ± .01	[0.] = [±.25]
Third Angle Projection	0.000 ± .005	[0.0] = [±.13]
All Dowel Holes are SF (Slip Fit). Locational Tolerance ±.0005" or [±.013mm]	0.0000 ± .0005	[0.00] = [±.013]
Metric Threads		
Course Pitch		

NOTE: Jaws have to be designed for a 0° gripping position (parallel jaws). Jaws will close 1.5° past parallel. To limit shocks at the end of an opening or closing stroke, it is highly recommended to design jaws with minimal inertia (as light and short as possible). Flow Controls make it possible to reduce the rotation speed and are highly recommended.

Loading Information

How to Order: (Order Accessories separately from Basic Model)

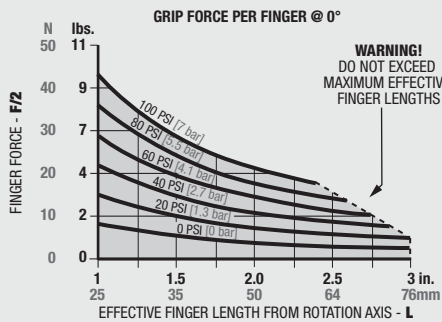

WARNING!
DO NOT EXCEED
MAXIMUM EFFECTIVE
FINGER LENGTHS

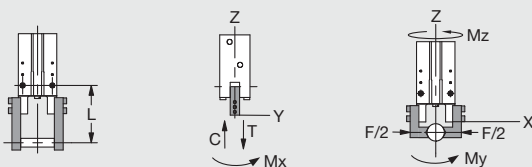

Loading Capacity†

	Static		Dynamic	
	Imperial	Metric	Imperial	Metric
Maximum Tensile T	20 lbs.	90 N	4 lbs.	18 N
Maximum Compressive C	20 lbs.	90 N	4 lbs.	18 N
Maximum Moment M_x	26 in.-lbs.	2.9 Nm	6 in.-lbs.	0.7 Nm
Maximum Moment M_y	26 in.-lbs.	2.9 Nm	6 in.-lbs.	0.7 Nm
Maximum Moment M_z	26 in.-lbs.	2.9 Nm	6 in.-lbs.	0.7 Nm

†Capacities are per set of jaws and are not simultaneous

BASIC MODEL VITON® SEALS

DCT-16M-RE-V

SIZE SPRING

NOTE: DCT-16-RE can be used as an exact replacement for CT-16-RE

SENSOR ACCESSORIES*

	ORDER #	QTY/UNIT
PNP Magneto Resistive Sensor Short Barrel w/Qk Disc*	OHSP-017	1 or 2
NPN Magneto Resistive Sensor Short Barrel w/Qk Disc*	OHNS-017	1 or 2
Inductive Sensor Mounting Kit (mounts 2 sensors)	SDCT16-20	1
4mm PNP Inductive Sensor with Quick Disconnect*	OISP-014	1 or 2
4mm NPN Inductive Sensor with Quick Disconnect*	OISN-014	1 or 2
Quick Disconnect 2 Meter Cable Length*	CABL-010	1 or 2
Quick Disconnect 5 Meter Cable Length*	CABL-013	1 or 2

PNEUMATIC ACCESSORIES

Adj. Flow Control M5 Elbow - 6mm OD Push-in (Metric)	VLVF-008	1 or 2
Buna-N Seal Repair Kit	SLKT-160	1
Viton® Seal Repair Kit	SLKT-160V	1

MOUNTING ACCESSORIES

Adjustment Stop Kit (1 Shielded Plate + 1 Stop)	KP-DCT16-BR	1
---	--------------------	----------

*Sensor and cable sold separately.

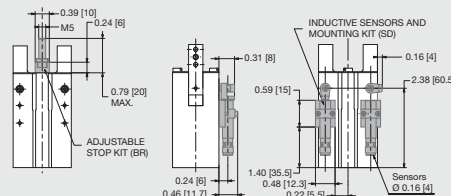

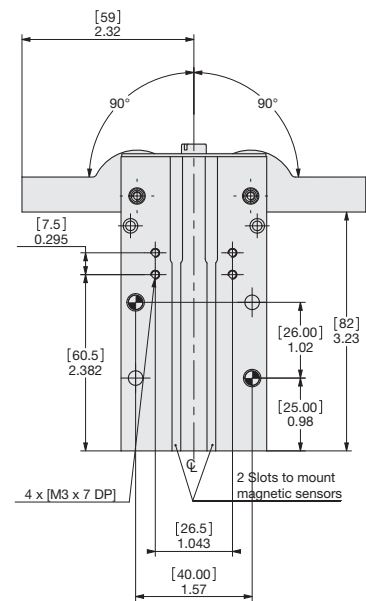
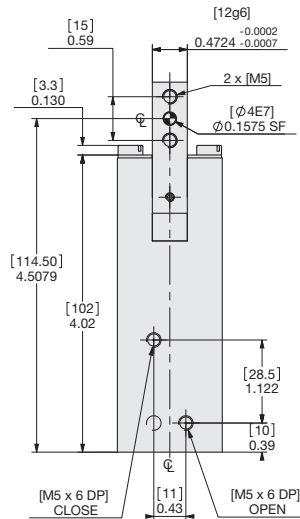
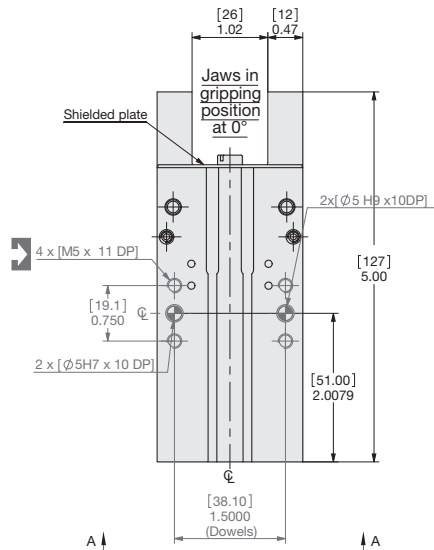

Specifications

DCT-25M-RE

Total Rated Grip Force, F @ 100 psi [7 bar]	45 lbs.	199 N
L = 1.75 in. [44mm] @ 0°	90° of stroke for each finger	
Stroke	1.26 lbs.	0.57 Kg
Weight	60-100 psi	4-7 Bar
Pressure Range	0.984 in.	25 mm
Cylinder Bore Ø	0.909 in ³	14.9 cm ³
Displacement	Temperature Range	
Temperature Range	Standard Seals	-30°~180° F -35°~80° C
Standard Seals	Viton® Seals	-20°~300° F -30°~150° C
Viton® Seals	Actuation (open/close)	0.25 / 0.19 sec.
Actuation (open/close)	Accuracy	±0.003 in. ±0.08 mm
Accuracy	Repeatability	±0.002 in. ±0.05 mm.
Repeatability	Valve required to actuate single acting	3-way, 2-position
Valve required to actuate single acting	Valve required to actuate double acting	4-way, 2-position

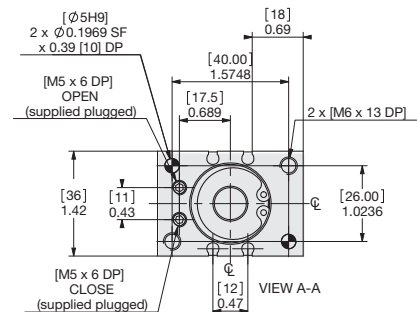
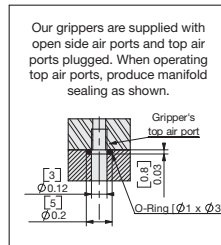

UNLESS OTHERWISE NOTED ALL TOLERANCES ARE AS SHOWN BELOW

Dimensions are symmetrical about centerline	Third Angle Projection	All Dowel Holes are SF (Slip Fit). Locational Tolerance ±.0005" or (±.013mm)	Metric Threads Course Pitch	Imperial in. 0.00 = ±.01 0.000 = ±.005 0.0000 = ±.0005	Metric [mm] [0.] = (±.25) [0.0] = (±.13) [0.00] = (±.013)
---	------------------------	--	-----------------------------	--	---

NOTE: Jaws have to be designed for a 0° gripping position (parallel jaws). Jaws will close 1.5° past parallel. To limit shocks at the end of an opening or closing stroke, it is highly recommended to design jaws with minimal inertia (as light and short as possible). Flow Controls make it possible to reduce the rotation speed and are highly recommended.

Loading Information

How to Order: (Order Accessories separately from Basic Model)

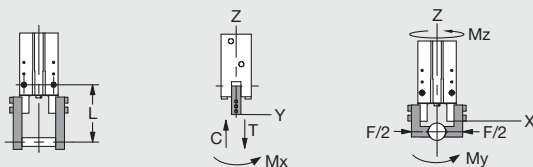
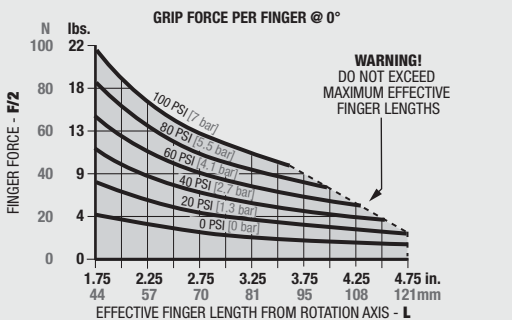

Loading Capacity†

	Static		Dynamic	
	Imperial	Metric	Imperial	Metric
Maximum Tensile T	46 lbs.	205 N	9 lbs.	41 N
Maximum Compressive C	46 lbs.	205 N	9 lbs.	41 N
Maximum Moment M_x	89 in.-lbs.	10 Nm	22 in.-lbs.	2.5 Nm
Maximum Moment M_y	89 in.-lbs.	10 Nm	22 in.-lbs.	2.5 Nm
Maximum Moment M_z	89 in.-lbs.	10 Nm	22 in.-lbs.	2.5 Nm

†Capacities are per set of jaws and are not simultaneous

BASIC MODEL VITON® SEALS

DCT-25M-RE-V
SIZE SPRING

SENSOR ACCESSORIES*

	ORDER #	QTY/UNIT
PNP Magneto Resistive Sensor Short Barrel w/Qk Disc*	OHSP-017	1 or 2
NPN Magneto Resistive Sensor Short Barrel w/Qk Disc*	OHSN-017	1 or 2
Inductive Sensor Mounting Kit (mounts 2 sensors)	SDCT25-32	1
M8 PNP Inductive Sensor with Quick Disconnect*	OISP-011	1 or 2
M8 NPN Inductive Sensor with Quick Disconnect*	OISN-011	1 or 2
Quick Disconnect 2 Meter Cable Length*	CABL-010	1 or 2
Quick Disconnect 5 Meter Cable Length*	CABL-013	1 or 2

PNEUMATIC ACCESSORIES

M5 Adjustable Flow Control	VLVF-008	1 or 2
Buna-N Seal Repair Kit	SLKT-162	1
Viton® Seal Repair Kit	SLKT-162V	1

MOUNTING ACCESSORIES

Adjustment Stop Kit (1 Shielded Plate + 1 Stop)	KP-DCT25-BR	1
---	--------------------	----------

*Sensor and cable sold separately.

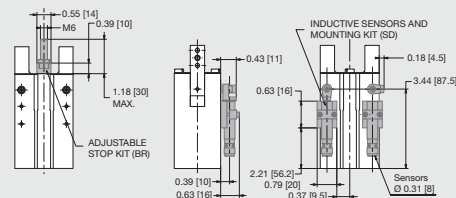

ANGULAR GRIPPER CT-32M-RE 180° SERIES



DCT-RE SERIES

2.50

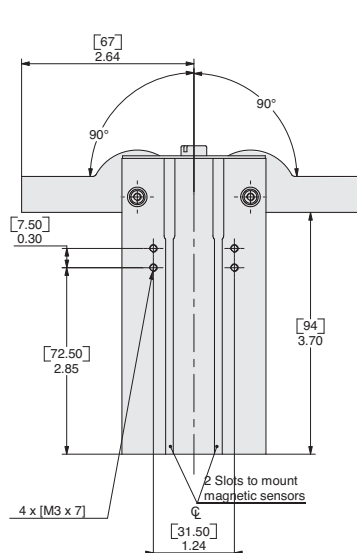
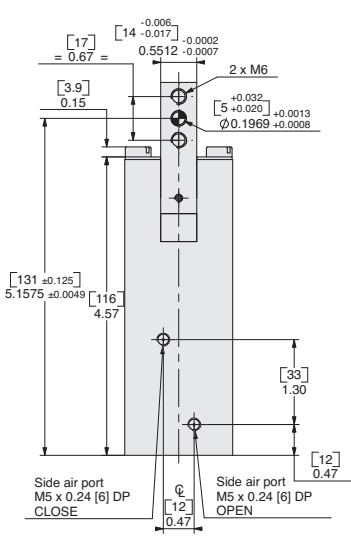
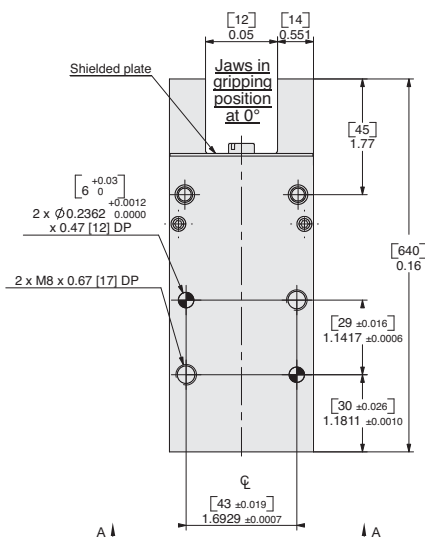

Specifications

Total Rated Grip Force, **F** @ 100 psi [7 bar]

	79 lbs.	353 N
Stroke	90° of stroke for each finger	
Weight	1.83 lbs.	0.83 Kg
Pressure Range	60-100 psi	4-7 Bar
Cylinder Bore Ø	1.260 in.	32 mm
Displacement	1.745 in ³	28.6 cm ³
Temperature Range		
Standard Seals	-30°~180° F	-35°~80° C
Viton® Seals	-20°~300° F	-30°~150° C
Actuation (open/close)	0.35 / 0.26 sec.	
Accuracy	±0.003 in.	±0.08 mm
Repeatability	±0.002 in.	±0.05 mm
Valve required to actuate single acting	3-way, 2-position	
Valve required to actuate double acting	4-way, 2-position	

CT-32M-RE

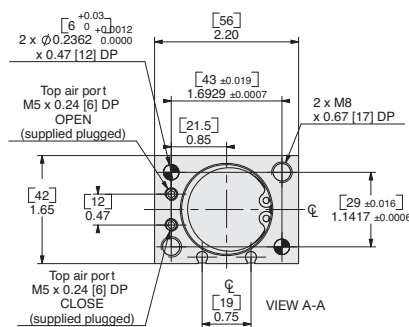
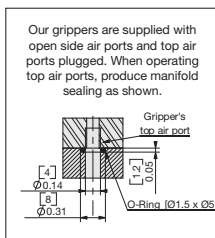

UNLESS OTHERWISE NOTED ALL TOLERANCES ARE AS SHOWN BELOW

Dimensions are symmetrical about centerline	Third Angle Projection	All Dowel Holes are SF (Slip Fit). Locational Tolerance ±.0005" or (±.013mm)	Metric Threads Course Pitch	Imperial in. 0.00 = ±.01 0.000 = ±.005 0.0000 = ±.0005	Metric [mm] [0.] = [±.25] [0.] = [±.13] [0.0] = [±.013]
---	------------------------	--	-----------------------------	--	---

NOTE: Jaws have to be designed for a 0° gripping position (parallel jaws). Jaws will close 1.5° past parallel. To limit shocks at the end of an opening or closing stroke, it is highly recommended to design jaws with minimal inertia (as light and short as possible). Flow Controls make it possible to reduce the rotation speed and are highly recommended.

Loading Information

How to Order: (Order Accessories separately from Basic Model)

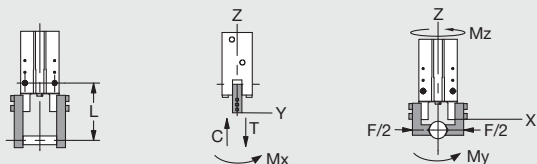
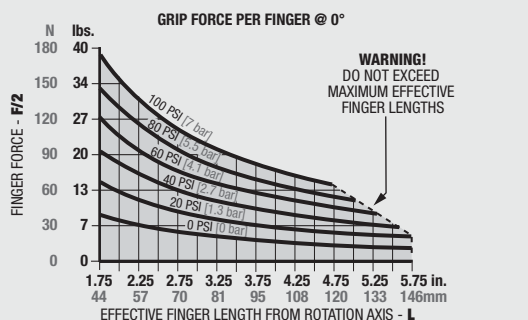

Loading Capacity†

	Static		Dynamic	
	Imperial	Metric	Imperial	Metric
Maximum Tensile T	65 lbs.	288 N	13 lbs.	57.6 N
Maximum Compressive C	65 lbs.	288 N	13 lbs.	57.6 N
Maximum Moment M_x	142 in.-lbs.	16 Nm	35 in.-lbs.	4 Nm
Maximum Moment M_y	142 in.-lbs.	16 Nm	35 in.-lbs.	4 Nm
Maximum Moment M_z	142 in.-lbs.	16 Nm	35 in.-lbs.	4 Nm

†Capacities are per set of jaws and are not simultaneous

BASIC MODEL **VITON® SEALS**
CT - 32M - RE - V
SIZE **SPRING**

SENSOR ACCESSORIES*

	ORDER #	QTY/UNIT
PNP Magneto Resistive Sensor Short Barrel w/Qk Disc*	OHSP-017	1 or 2
NPN Magneto Resistive Sensor Short Barrel w/Qk Disc*	OHSN-017	1 or 2
Inductive Sensor Mounting Kit (mounts 2 sensors)	SDC25-32	1
M8 PNP Inductive Sensor with Quick Disconnect*	OISP-011	1 or 2
M8 NPN Inductive Sensor with Quick Disconnect*	OISN-011	1 or 2
Quick Disconnect 2 Meter Cable Length*	CABL-010	1 or 2
Quick Disconnect 5 Meter Cable Length*	CABL-013	1 or 2

PNEUMATIC ACCESSORIES

Adj. Flow Control M5 Elbow - 6mm OD Push-in (Metric)	VLVF-008	1 or 2
Buna-N Seal Repair Kit	SLKT-163	1
Viton® Seal Repair Kit	SLKT-163V	1

MOUNTING ACCESSORIES

Adjustment Stop Kit (1 Shielded Plate + 1 Stop)	KP-CT32-BR	1
---	-------------------	----------

*Sensor and cable sold separately.

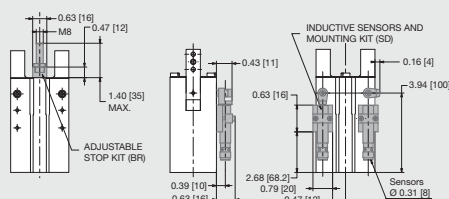

ANGULAR GRIPPER CT-50M-RE 180° SERIES



DCT-RE SERIES

2.52

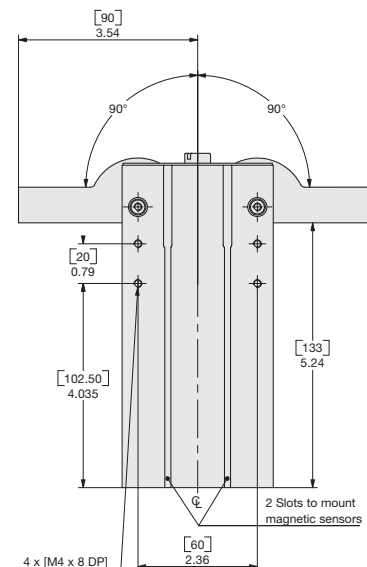
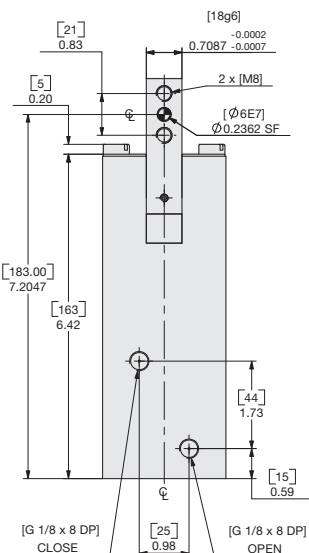
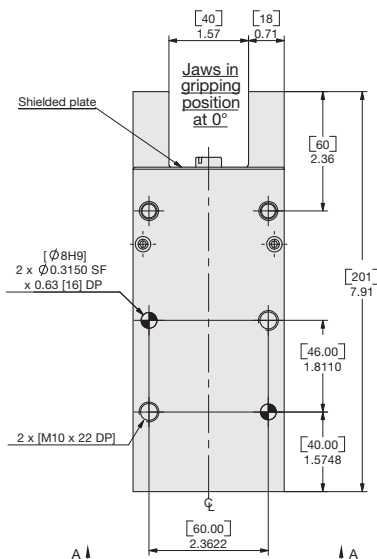

Specifications

CT-50M-RE

Total Rated Grip Force, F @ 100 psi [7 bar]	201 lbs.	893 N
L = 2.5 in. [64mm] @ 0°		
Stroke	90° of stroke for each finger	
Weight	4.87 lbs.	2.21 Kg
Pressure Range	60-100 psi	4-7 Bar
Cylinder Bore Ø	1.968 in.	50 mm
Displacement	5.614 in ³	92 cm ³
Temperature Range		
Standard Seals	-30°~180° F	-35°~80° C
Viton® Seals	-20°~300° F	-30°~150° C
Actuation (open/close)	0.54 / 0.42 sec.	
Accuracy	±0.0036 in.	±0.09 mm
Repeatability	±0.002 in.	±0.05 mm.
Valve required to actuate single acting	3-way, 2-position	
Valve required to actuate double acting	4-way, 2-position	

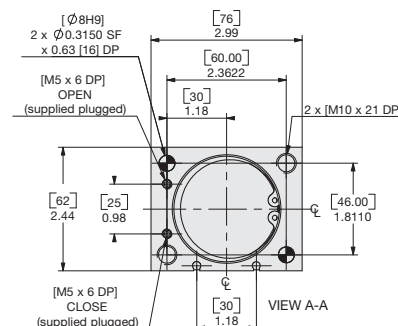
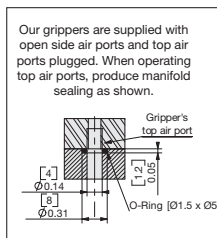

UNLESS OTHERWISE NOTED ALL TOLERANCES ARE AS SHOWN BELOW

Dimensions are symmetrical about centerline	Third Angle Projection	All Dowel Holes are SF (Slip Fit). Locational Tolerance ±.0005" or ±.013mm	Metric Threads Course Pitch	Imperial in. 0.00 = ±.01 0.000 = ±.005 0.0000 = ±.0005	Metric [mm] [0.] = ±.25 [0.] = ±.13 [0.0] = ±.013
---	------------------------	--	-----------------------------	--	---

NOTE: Jaws have to be designed for a 0° gripping position (parallel jaws). Jaws will close 1.5° past parallel. To limit shocks at the end of an opening or closing stroke, it is highly recommended to design jaws with minimal inertia (as light and short as possible). Flow Controls make it possible to reduce the rotation speed and are highly recommended.

Loading Information

How to Order: (Order Accessories separately from Basic Model)

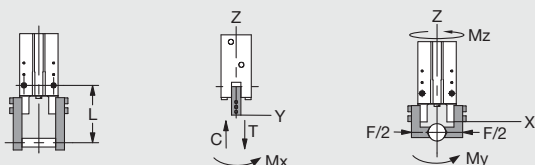
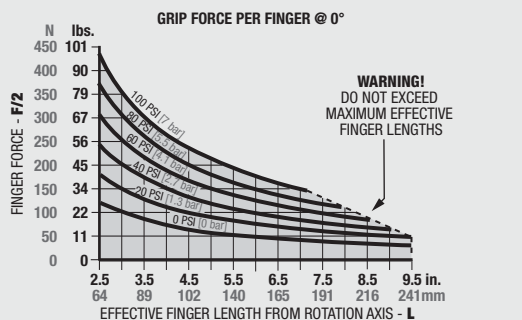

Loading Capacity [†]	Static		Dynamic	
	Imperial	Metric	Imperial	Metric
Maximum Tensile T	110 lbs.	490 N	22 lbs.	98 N
Maximum Compressive C	110 lbs.	490 N	22 lbs.	98 N
Maximum Moment M_x	266 in.-lbs.	30 Nm	66 in.-lbs.	7.5 Nm
Maximum Moment M_y	266 in.-lbs.	30 Nm	66 in.-lbs.	7.5 Nm
Maximum Moment M_z	266 in.-lbs.	30 Nm	66 in.-lbs.	7.5 Nm

[†]Capacities are per set of jaws and are not simultaneous

BASIC MODEL VITON® SEALS

CT-50M-RE-V
SIZE SPRING

SENSOR ACCESSORIES*

	ORDER #	QTY/UNIT
PNP Magneto Resistive Sensor Short Barrel M8 w/Qk Disc*	OHSP-017	1 or 2
NPN Magneto Resistive Sensor Short Barrel M8 w/Qk Disc*	OHSN-017	1 or 2
Inductive Sensor Mounting Kit (mounts 2 sensors)	SDCT40-63	1
M12 NPN Inductive Sensor with Quick Disconnect*	OISP-017	1 or 2
M12 NPN Inductive Sensor with Quick Disconnect*	OISN-017	1 or 2
M8 Quick Disconnect 2 Meter Cable Length*	CABL-010	1 or 2
M8 Quick Disconnect 5 Meter Cable Length*	CABL-013	1 or 2
M12 Quick Disconnect 2 Meter Cable Length*	CABL-014	1 or 2
M12 Quick Disconnect 5 Meter Cable Length*	CABL-018	1 or 2

PNEUMATIC ACCESSORIES

Adj. Flow Control G1/8 Elbow - 6mm OD Push-in (Metric)	VLVF-005	1 or 2
Buna-N Seal Repair Kit	SLKT-165	1
Viton® Seal Repair Kit	SLKT-165V	1

MOUNTING ACCESSORIES

Adjustment Stop Kit (1 Shielded Plate + 1 Stop)	KP-CT50-BR	1
---	-------------------	----------

*Sensor and cable sold separately.

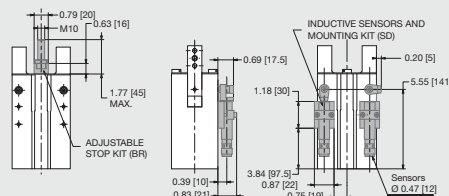

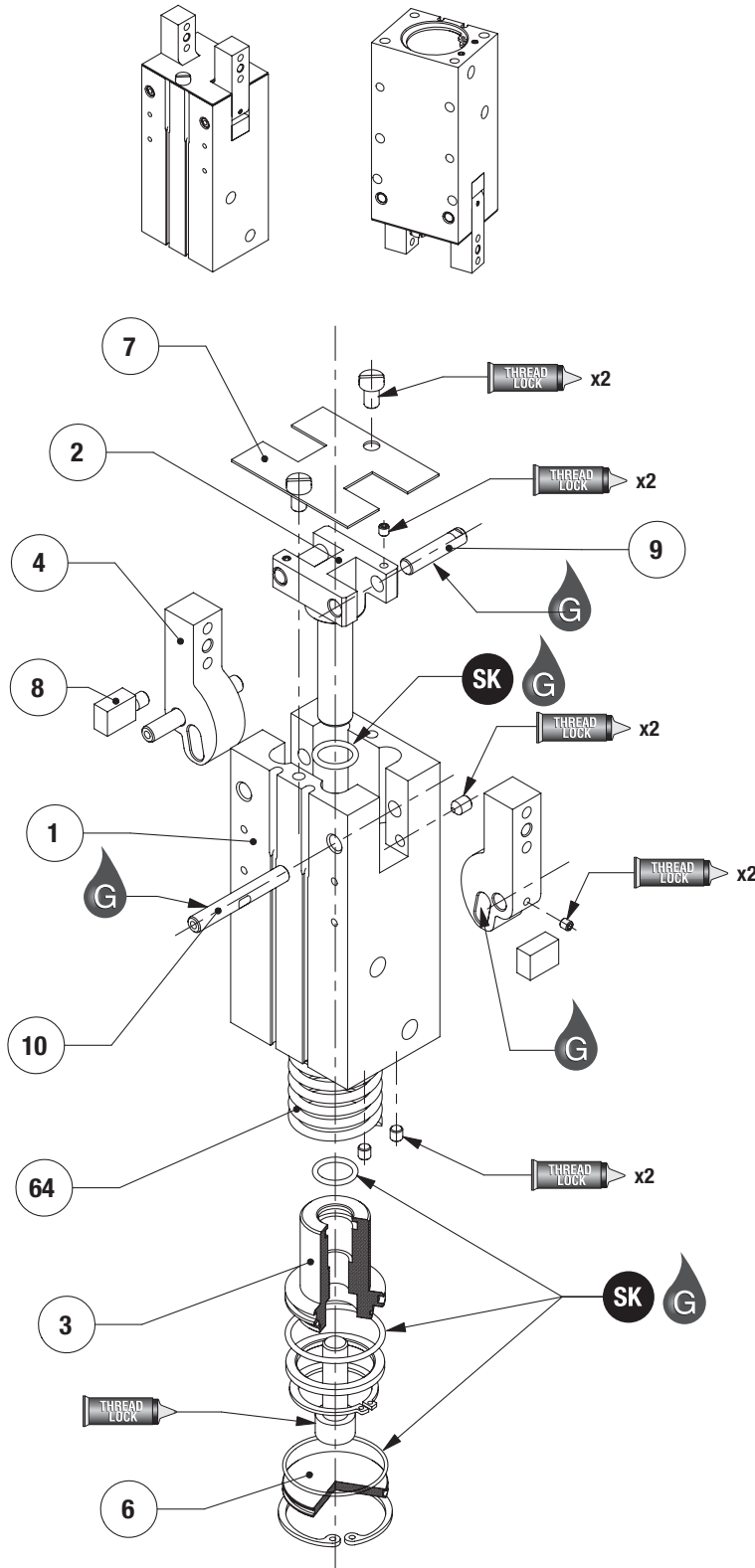

Item	Qty	Name
01	1	Body
02	1	Driver
03	1	Piston
04	2	Jaw
05	1	Washer
06	1	Cap
07	1	Shielded Plate
08	2	Wiper Cover
09	2	Drive Pin
10	2	Pivot Pin
54	1	Magnet
64	1	Spring

NOTE: Contact the Robohand Sales Department for a complete spare parts list with order numbers and prices.

Assembly Procedure

- Lubricate and install the seals into cap (x1), piston (x2) and body (x1)
- If top air ports are used, clear them and plug the side air ports on the body (#1)
- Lubricate the sloping rack of jaws (#4)
- Install both drive pins (#9) into driver (#2) through sloping racks of jaws. Check that the pin flat surface is correctly aligned before continuing with their installation.
- Lock drive pins in the driver with screws, tightening down on to the flat surface of the pins.
- Position driver and jaws assembly into body.
- Install both pivot pins (#10) into body, through the bore of jaws. Check that the pin flat surface is correctly aligned before continuing with their installation.
- Pivot pin locking:
 - DCT-12 (not shown): lock pivot pins into body with screws, tightening down on to the flat surface of the pins (pins are fixed into body and rotating into jaws)
 - DCT-16 to CT-50: lock pivot pins into jaws with screws, tightening down on to the flat surface of the pins (pins are fixed into jaws and rotating into body)
- Magnet mounting:
 - DCT-12 to DCT-20: install the magnet (#54) on the washer (#5)
 - DCT-25 to CT-50 (not shown): install magnet (#54) onto piston (#3) and lock it by means of its retaining ring.
- Piston mounting:
 - DCT-12 to DCT-20: insert the spring, then the piston and the washer with magnet into body. Fix the assembly at the end of the driver with screw.
 - DCT-25 to CT-50 (not shown): insert the spring, then the piston with magnet into body. Fix the assembly at the end of the drivers with screw.
- Check unit operation unladen.
- Install the cap (#6) into body and lock it by means of its retaining ring.
- Place both wiper covers (#8) into body and lock them with their screws.
- Fix the shielded plate (#7) onto body with both screws.

**SK Seal Repair Kit Order #'s
See Product Data Sheets**

Seal Kit Items	Thread Locker	Krytox™ Lubricant	Lightweight Machine Oil	Teflon™ Based Grease	Super Bonder	Third Angle Projection

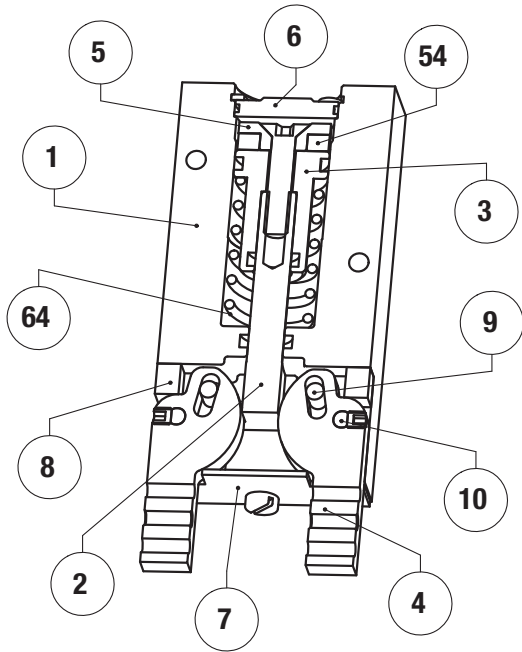

Item	Qty	Name
01	1	Body
02	1	Driver
03	1	Piston
04	2	Jaw
05	1	Washer
06	1	Cap
07	1	Shielded Plate
08	2	Wiper Cover
09	2	Drive Pin
10	2	Pivot Pin
54	1	Magnet
64	1	Spring

NOTE: Contact the Robohand Sales Department for a complete spare parts list with order numbers and prices.

ACCESSORY INSTALLATION & ADJUSTMENT INSTRUCTIONS

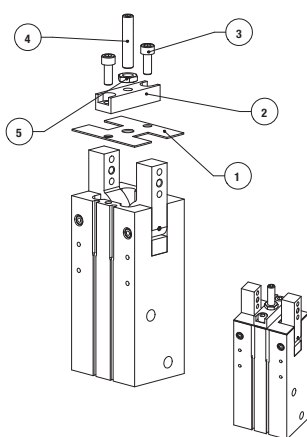

Installation - Adjustment Stop

- 1) Unscrew both screws for mounting of the shielded plate and remove it.
- 2) Fix the new shielded plate (#1) and the stop (#2) onto body with both screws (#3)
- 3) Install the locknut system (#4) and (#5) on the stop.
- 4) Tighten screw for maximum target jaw opening and lock with locknut.

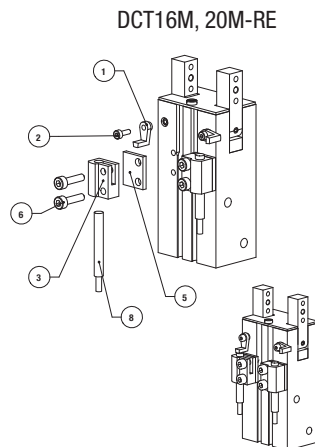

Installation - Inductive Sensor Holders

- 1) Fix the flags (#1) at the end of pivot pins with their screws (#2)
- 2) Holder mounting:
 - DCT-16M to DCT-32M: fix holder (#3) and spacer (#5) onto body with both screws (#6)
 - CT-40M to CT-50M: fix holder (#3) onto body with both screws (#6)
- 3) Sensor mounting:
 - DCT-16M to DCT-20M: unscrew lightly both screws for mounting (#6) of holder and insert sensor (#8, not included) into it. Position sensor so that it senses up on flag. Lock the sensor by tightening both screws.
 - DCT-25M to DCT-32M: unscrew lightly screw (#7) on holder and insert sensor (#8, not included) into it. Position sensor so that it senses up the flag. Lock the sensor by tightening screw.
 - CT-40M to CT-50M: insert sensor (#8, not included) in stop into holder. Lock the sensor by tightening the collar holder with both screws (not shown).
- 4) Adjust flag position by unscrewing their screws for desired sensing positions.

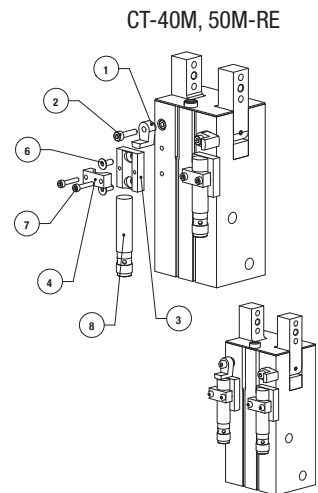
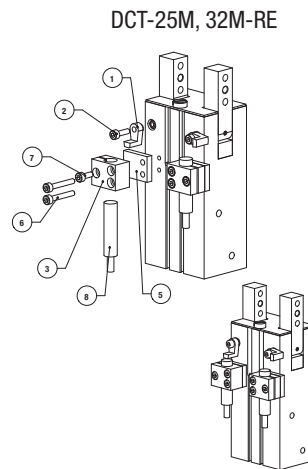

Seal Kit Items



Thread Locker



Krytox™ Lubricant



Lightweight Machine Oil



Teflon™ Based Grease



Super Bonder

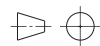

Third Angle Projection



DESIGN NOTES

DCT-RE/CT-RE
SERIES
MAINTENANCE

2.55

