



Flat-Tip Bonded
Neoprene Spindle
– Inch



Large Diameter
Padded Swivel Foot
Spindle – Inch



Neoprene Caps



Bolt Retainers



Flat-Tip Bonded
Neoprene Spindle
– Metric



Swivel Foot
Spindle



Special Neoprene Caps



Flanged Washers



Round Bonded
Neoprene Spindle
– Metric



Hex Head
Spindle



Polyurethane Caps



Cone-Tip Bonded
Neoprene Spindle
– Metric



Plunger-matic
Assemblies



Cone-Tip
Polyurethane Caps

Manual Accessories

Flat-Tip Bonded Neoprene Spindle – Inch

- Black neoprene, hardness: 70-80 Shore A
- Temperature Range: -20°C to 100°C [-22°F to 212°F]
- Oil resistant, LABS (silicone) free
- Includes jam nuts

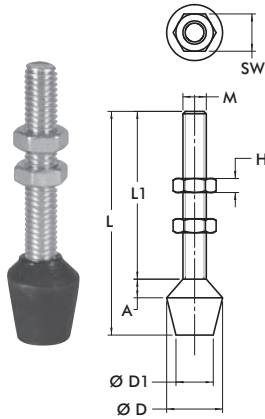

Part No.	M	L	L1	SW	H	A	ØD	ØD1
▲ 102208	#8-32	[1.25] 31,8	[0.94] 23,8	[0.34] 8,7	[0.13] 3,2	[0.06] 1,6	[0.56] 14,3	[0.44] 11,1
▲ 105208		[1.00] 25,4	[0.69] 17,4					
▲ 201208	#10-32	[1.38] 35,1	[1.01] 25,5	[0.38] 9,5		[0.13] 3,2		
▲ 202208	1/4-20	[1.63] 41,4	[1.08] 27,4	[0.44] 11,1	[0.16] 4	[0.12] 3	[0.63] 16	[0.47] 12
▲ 215208		2.13 54,1	[1.58] 40,1					
▲ 424208		[1.50] 38,1	[1.12] 28,5					
▲ 431208		[1.00] 25,4	[0.62] 15,8			[0.13] 3,3	[0.66] 16,8	[0.50] 12,7
▲ 225208	5/16-18	[2.25] 57,2	[1.54] 39,1	[0.50] 12,7	[0.19] 4,8		[0.83] 21	[0.55] 14
▲ 507208		[3.00] 76,2	[2.29] 58,2					
▲ 240208		[3.25] 82,6	[2.31] 58,5			[0.20] 5	[1.02] 26	[0.79] 20
▲ 527208	3/8-16	[3.50] 88,9	[2.50] 63,5	[0.56] 14,3	[0.22] 5,6		[0.88] 22,2	[0.63] 16
▲ 235208		[5.75] 146,1	[4.77] 121,1				[1.02] 26	[0.79] 20
▲ 247208	1/2-13	[3.87] 98,3	[2.73] 69,3	[0.75] 19,1	[0.31] 7,9	[0.28] 7	[1.18] 30	[0.95] 24
▲ 267208	5/8-11	[5.00] 127	[3.63] 92,1	[0.94] 23,8	[0.38] 9,5	[0.38] 9,5	[1.38] 35,1	[1.00] 25,4

Flat-Tip Bonded Neoprene Spindle – Metric

- Red neoprene, hardness: 80-85 Shore A
- Temperature Range: -20°C to 100°C [-22°F to 212°F]
- Oil resistant, LABS (silicone) free
- Includes jam nuts

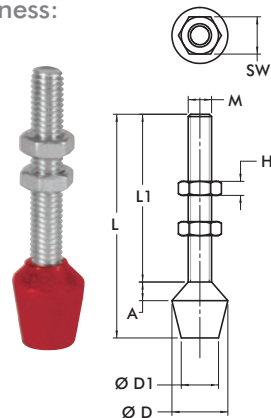

Part No.	M	L	L1	SW	H	A	ØD	ØD1
● 431208-M	M6	[1.00] 25,4	[0.6] 15,8	[0.39] 10	[0.13] 3,2	[0.13] 3,3	[0.66] 16,8	[0.66] 16,8
● 424208-M		[1.63] 41,3	[1.25] 31,7					
● 202208-M		[1.73] 44	[1.18] 30					
● 215208-M		[2.13] 54	[1.57] 40			[0.12] 3	[0.63] 16	[0.47] 12
● 225208-M	M8	[2.09] 53	[1.38] 35	[0.51] 13	[0.16] 4	[0.20] 5	[0.83] 21	[0.55] 14
● 2007208-M		[2.48] 63	[1.77] 45					
● 507208-M		[3.27] 83	[2.56] 65					
● 240208-M	M10	[3.11] 79	[2.17] 55	[0.67] 17	[0.20] 5		[1.02] 26	[0.78] 20
● 235208-M		[4.72] 120	[3.74] 95					
● 247208-M	M12	[4.02] 102	[2.87] 73	[0.75] 19	[0.24] 6	[0.28] 7	[1.18] 30	[0.94] 24

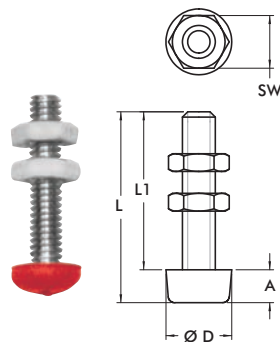

Part No.	M	L	L1	SW	H	A	ØD
● 205208-M	M4	[0.87] 22	[0.79] 20	[0.28] 7	[0.09] 2,2	[0.11] 2,8	[0.32] 8
● 201208-M		[1.26] 32	[1.18] 30				
● 305208-M	M5	[1.14] 29	[0.98] 25	[0.32] 8	[0.11] 2,7	[0.39] 10	[0.39] 10
● 213208-M		[1.34] 34	[1.18] 30				
● 2013208-M		[1.54] 39	[1.38] 35				
● 307208-M	M8	[1.69] 43		[0.51] 13	[0.16] 4	[0.75] 19	[0.75] 19

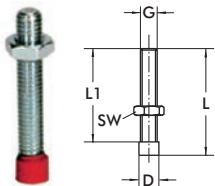

Part No.	D	L	L1	ØG
● 213208-M-L ⓘ	[0.24] 6	[1.34] 34	[1.18] 30	M5

ⓘ Item is available upon request.

Preferred Market: ▲ NA/SA ■ Europe ● Global

Cone-Tip Bonded Neoprene Spindle – Inch

- Black neoprene, hardness: 70-80 Shore A
- Temperature Range: -20°C to 100°C [-22°F to 212°F]
- Oil resistant, LABS (silicone) free
- Includes jam nuts

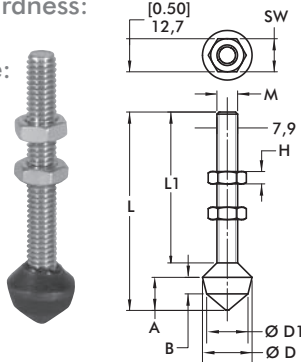

Part No.	M	L	L1	SW	H	A	B	ØD	ØD1
▲ 305208	#10-32	[1.50] 38,1	[1.00] 25,4	[0.38] 9,5	[0.13] 3,3	[0.38] 9,5	[0.19] 4,8	[0.56] 14,2	[0.44] 11,2
▲ 213208	1/4-20	[2.25] 57,2	[1.56] 39,6	[0.44] 11,2	[0.16] 4,0				
▲ 509208	5/16-18	[3.00] 76,2	[2.28] 57,9	[0.50] 12,7	[0.19] 4,8	[0.50] 12,7	[0.25] 6,4	[0.75] 19,1	[0.63] 16
▲ 519208		[5.50] 139,7	[4.75] 120,7						
▲ 210208	3/8-16	[3.50] 88,9	[2.50] 63,5	[0.56] 14,2	[0.23] 5,8	[0.75] 19,1	[0.41] 10,4	[0.88] 22,4	[0.75] 19,1

Large Diameter Padded Swivel Foot Spindle-Inch

- White neoprene, hardness: 70-80 Shore A
- Temperature Range: -40°C to 105°C [-40°F to 220°F]
- Non-marking neoprene
- Includes jam nuts

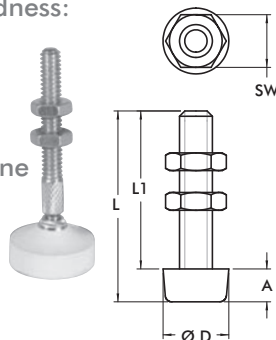

Part No.	M	L	L1	SW	H	A	ØD	Swivel Angle
▲ 207209	1/4-20	[2.56] 65	[1.56] 39,6	[0.44] 11,2	[0.16] 4		[1.00] 25,4	14°
▲ 507209	5/16-18	[2.98] 75,7	[1.94] 49,3	[0.50] 12,7	[0.19] 4,8	[0.31] 8	[1.50] 38,1	24°
▲ 210209	3/8-16	[3.56] 90,4	[2.44] 62	[0.56] 14,2	[0.23] 5,8		[2.00] 50,8	26°

Plunger-matic Assemblies

- For use with Straight Line Action clamps
- Internal compression spring compensates for variations in material thickness
- Zinc plated
- Includes jam nut

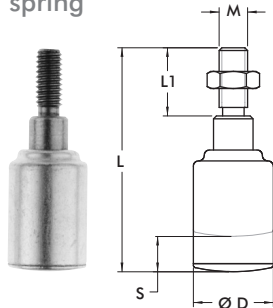

Part No.	M	L	L1	ØD	Max. Compression S	Spring Constant [lbf./in] N/mm	Max. Force [lbf.] N
▲ 905	5/16-18	[2.50] 63,5	[0.75] 19,1		[0.19] 4,8	[750] 131	[135] 600
● 905-M	M8			[0.88] 22,2			
▲ 920	3/8-16	[3.63] 92,2	[1.13] 28,6		[0.38] 9,6	[822] 144	[308] 1370
● 920-M	M10						

Swivel Foot Spindle

- Includes jam nuts

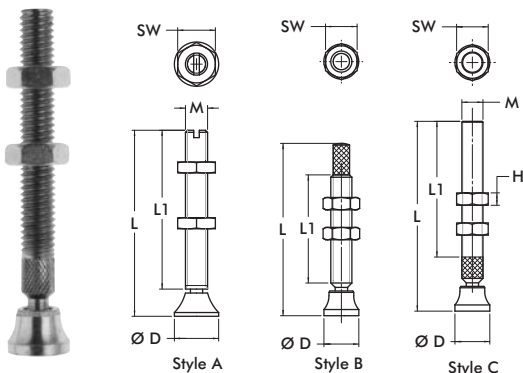

Part No.	M	Style	L	L1	SW	H	ØD	Swivel Angle
■ 207206-M	M6	A	[2.44] 62	[2.13] 54	[0.39] 10	[0.13] 3,2	[0.47] 12	30°
■ 507206-M	M8		[2.87] 73	[2.46] 62,5	[0.51] 13	[0.16] 4	[0.63] 16	
▲ 468206-M	M10	B	[3.00] 76,2	[2.00] 50,8	[0.67] 17	[0.20] 5	[0.79] 20	24°
■ 210206-M		A	[3.31] 84	[2.80] 71			[0.79] 20	
■ 250206-M	M12	A	[4.72] 120	[4.13] 105	[0.75] 19	[0.24] 6	[0.98] 25	30°
▲ 207206	1/4-20	C	[2.38] 60,5	[1.56] 39,6	[0.44] 11,2	[0.16] 4	[0.50] 12,7	14°
▲ 507206	5/16-18		[2.75] 69,9	[1.94] 49,3	[0.50] 12,7	[0.19] 4,8	[0.56] 14,2	
▲ 468206	3/8-16	B	[3.06] 77,7	[1.92] 48,8	[0.56] 14,2	[0.23] 5,8	[0.63] 16	24°
▲ 210206		C	[3.38] 85,9	[2.41] 61,2			[0.63] 16	
▲ 250206	1/2-13	C	[4.63] 117,6	[3.44] 87,4	[0.75] 19,1	[0.31] 7,9	[1.00] 25,4	24°

Preferred Market: ▲ NA/SA ■ Europe ● Global

Manual Accessories

Hex Head Spindle – Stainless Steel

- Includes Plain hexagonal head
- Includes Fully threaded
- Includes Stainless steel, type 303
- Includes jam nuts

Part No.	M	L	L1	SW	H	Part No.	M	L	L1	SW	H
● 205943-M	M4	[0.89] 22	[0.79] 20	[0.28] 7	[0.09] 2,2	▲ 205943	#8-32	[0.86] 21,8	[0.75] 19,1	[0.25] 6,4	[0.13] 3,2
● 201943-M	M5	[1,32] 33,5	[1.18] 30	[0.31] 8	[0.11] 2,7	▲ 201943	#10-32	[1,37] 34,8	[1,37] 34,8	[0.31] 8	
● 202943-M	M6	[1.73] 42,4	[1.57] 40	[0.39] 10	[0.13] 3,2	▲ 202943	1/4-20	[1.67] 42,4	[1.50] 38,1	[0.44] 11,1	[0.16] 4
● 207943-M	M8	[2.77] 70,3	[2.56] 65	[0.51] 13	[0.16] 4	▲ 207943	5/16-18	[2.72] 69	[2.50] 63,5	[0.50] 12,7	[0.19] 4,8
● 237943-M	M10	[3.00] 76,4	[2.76] 70	[0.67] 17	[0.20] 5	▲ 237943	3/8-16	[2.75] 69,9	[2.50] 63,5	[0.56] 14,2	[0.22] 5,6
● 245943-M	M12	[2.87] 73	[2.56] 65	[0.75] 19	[0.24] 6	▲ 245943	1/2-13	[2.72] 69	[2.38] 60,5	[0.75] 19,1	[0.31] 8

Hex Head Spindle

- Plain hexagonal head
- Fully threaded
- Zinc plated
- Includes jam nuts

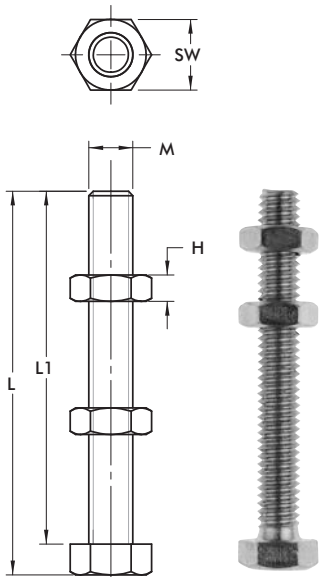

Part No.	M	L	L1	SW	H	Part No.	M	L	L1	SW	H
● 205203-M	M6	[1.93] 49	[1.77] 45	[0.39] 10	[0.13] 3,2	▲ 205203	1/4-20	[1.92] 48,8	[1.75] 44,5	[0.44] 11,2	[0.16] 4
▲ 461203-M	M8	[1.20] 30,5	[0.98] 25	[0.51] 13	[0.16] 4	▲ 202203		[3.17] 80,5	[3.00] 76,2		
● 207203-M		[2.97] 75,5	[2.76] 70			▲ 461203	[1.22] 31	[1.00] 25,4			
▲ 491203-M	M10	[1.85] 47	[1.57] 40			▲ 441203	5/16-18	[1.97] 50	[1.75] 44,5	[0.50] 12,7	[0.19] 4,8
● 210203-M		[3.03] 77	[2.76] 70	[0.67] 17	[0.20] 5	▲ 207203		[2.72] 69,1	[2.50] 63,5		
▲ 240203-M		[4.21] 107	[3.94] 100			▲ 491203		[1.75] 44,5	[1.50] 38,1		
● 220203-M	M12	[3.46] 88	[3.15] 80	[0.75] 19	[0.24] 6	▲ 210203	3/8-16	[3.00] 76,2	[2.75] 69,9	[0.56] 14,2	[0.23] 5,8
● 267203-M	M16	[5.12] 130	[4.72] 120	[0.94] 24	[0.28] 7	▲ 240203		[4.25] 108	[4.00] 101,6		
▲ 105203*	#8-32	[0.86] 21,8	[0.75] 19,1	[0.25] 6,4	[0.13] 3,3	▲ 527203		[5.25] 133,4	[5.00] 127		
▲ 305203	#10-32	[1.12] 28,4	[1.00] 25,4	[0.31] 8		▲ 325203	1/2-13	[2.84] 72,1	[2.50] 63,5	[0.75] 19,1	[0.31] 7,9
						▲ 220203		[3.34] 84,8	[3.00] 76,2		
						▲ 250203	5/8-11	[4.42] 101,6	[4.00] 101,6	[0.38] 9,5	[0.38] 9,5

*Material: nylon

Preferred Market: ▲ NA/SA ■ Europe ● Global

Neoprene Caps

- Slip on head of hex-head spindles
- Hardness: 60-70 Shore A
- Temperature range:
-40°C to 105°C [-40°F to 220°F]

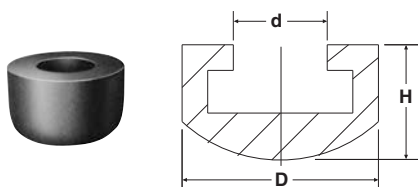

Part No.	D	d	H	For Spindle Diameter
● 215119	[0.63] 16	[2.50] 63,5	[0.44] 11,1	M6 or 1/4
● 225119	[0.75] 19,1	[0.31] 8	[0.50] 12,7	M8 or 5/16
● 235119	[0.88] 22,3	[0.38] 9,7	[0.53] 13,5	M10 or 3/8

Special Neoprene Caps

- Slip on threaded spindle rod
- Hardness: 60-70 Shore A
- Temperature range:
-40°C to 105°C [-40°F to 220°F]

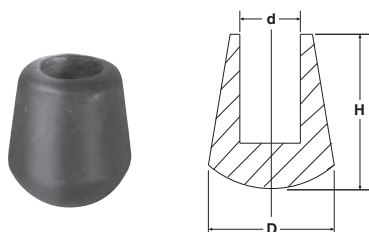

Part No.	D	d	H	For Spindle Diameter
▲ 424107	[0.44] 11,1	[0.22] 5,6	[0.44] 11,1	M6 or 1/4
▲ 235110	[0.72] 18,3	[0.34] 8,6	[0.88] 22,3	M10 or 3/8

Polyurethane Caps

- Flat tip, internally threaded
- Hardness: 80 Shore A
- Temperature range:
-70°C to 95°C [-90°F to 200°F]

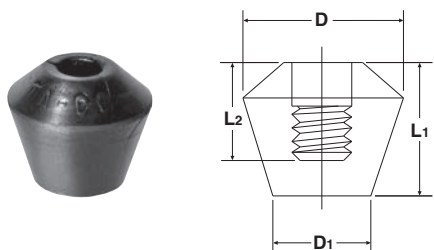

Part No.	D	D1	L1	L2	For Spindle Diameter
▲ 215219	[0.79] 20	[0.50] 12,7	[0.69] 17,5	[0.50] 12,7	1/4
▲ 225219	[0.81] 20,5	[0.63] 16	[0.88] 22,3	[0.63] 16	5/16
▲ 235219	[0.81] 20,5	[0.63] 16	[0.88] 22,3	[0.63] 16	3/8

Polyurethane Caps – Cone-tip

- Cone tip, internally threaded
- Hardness: 80 Shore A
- Temperature range:
-70°C to 95°C [-90°F to 200°F]

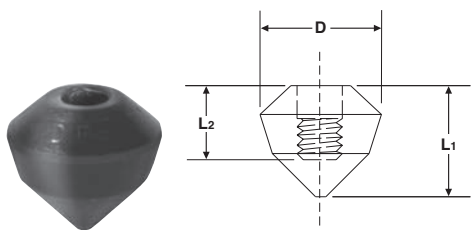

Part No.	D	L1	L2	For Spindle Diameter
▲ 215319	[0.81] 20,5	[0.75] 19,1	[0.50] 12,7	1/4
▲ 225319	[0.81] 20,5	[0.94] 23,9	[0.63] 16	5/16
▲ 235319	[0.81] 20,5	[0.94] 23,9	[0.63] 16	3/8

Preferred Market: ▲ NA/SA ■ Europe ● Global

Manual Accessories

Bolt Retainers –

- For use with clamps featuring U-bar and open bar clamping arms

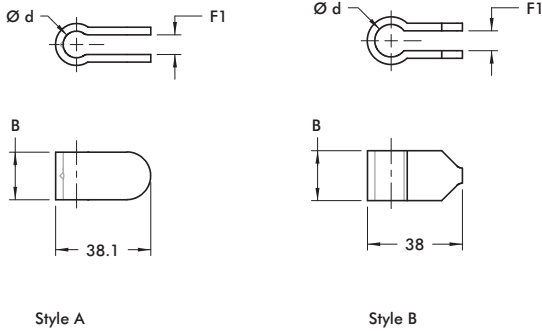

Part No.	A	B	Ød	F1	For Spindle Diameter	Style
▲ 207105	[1.25] 31,8	[0.63] 16	[0.33] 8,4	[0.25] 6,4	M8 or 5/16	A
■ 207105-M	[1.26] 32		[0.32] 8,2	[0.24] 6		B
▲ 210114	[1.50] 38,1	[0.75] 19,1	[0.53] 13,5	[0.31] 8	M10 or 3/8	A
■ 210114-M	[1.49] 38	[0.78] 20	[0.51] 13			B
▲ 247110	[1.63] 41,4	[0.88] 22,3	[0.56] 14,2	[0.38] 9,7	M12 or 1/2	A
■ 247110-M	[1.61] 41	[0.87] 22,2	[0.57] 14,4			B
● 110122	[1.88] 47,8	[1.25] 31,8	[0.64] 16,3	[0.23] 5,8	M16 or 5/8	A
▲ 250121		[1.00] 25,4			M12 or 1/2	A
● 2002115-E	[0.97] 24,6	[0.50] 12,7	[0.26] 6,6	[0.23] 5,8	M6 or 1/4	B
● 2007115-E	[1.26] 32	[0.75] 19,1	[0.34] 8,6		M8 or 5/16	
● 2010115-E	[1.58] 40,1	[1.13] 28,7	[0.41] 10,4		M10 or 3/8	

Flanged Washers –

- For use with clamps featuring U-bar and open bar clamping arms
- Zinc plated

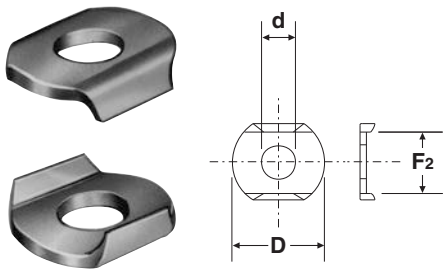

Part No.	ØD	Ød	F2	For Spindle Diameter
● 105106	[0.44] 11,2	[0.17] 4,3	[0.33] 8,3	M4 or #8
● 102111	[0.56] 14,2	[0.20] 5,1	[0.38] 9,6	M5 or #10
● 215105	[0.69] 17,5	[0.26] 6,7	[0.50] 12,7	M6 or 1/4
● 507107	[0.88] 22,4	[0.33] 8,4	[0.59] 15	M8 or 5/16
● 235106	[1.00] 25,4	[0.41] 10,5	[0.75] 19,1	M10 or 3/8
● 247109	[1.26] 32	[0.53] 13,5	[0.91] 23,2	M12 or 1/2
● 267102	[1.44] 36,5	[0.66] 16,8	[1.03] 26,2	M16 or 5/8

Flanged Washers-Stainless Steel

- For use with clamps featuring U-bar and open bar clamping arms

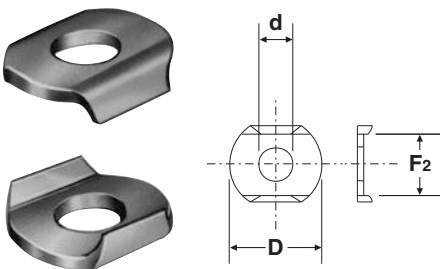

Part No.	ØD	Ød	F2	For Spindle Diameter
● 105906	[0.44] 11,2	[0.17] 4,3	[0.33] 8,3	M4 or #8
● 102911	[0.56] 14,2	[0.20] 5,1	[0.38] 9,6	M5 or #10
● 215905	[0.69] 17,5	[0.26] 6,7	[0.50] 12,7	M6 or 1/4
● 507907	[0.88] 22,4	[0.33] 8,4	[0.60] 15,2	M8 or 5/16
● 235906	[1.00] 25,4	[0.41] 10,5	[0.75] 19,1	M10 or 3/8
● 247909	[1.26] 32	[0.53] 13,5	[0.91] 23,2	M12 or 1/2
● 267902	[1.44] 36,6	[0.66] 16,8	[1.03] 26,2	M16 or 3/8

Preferred Market: ▲ NA/SA ■ Europe ● Global

Adapters & Extensions

Features:

- Provides flexible adjustment of length and height
- Mounts to manual clamp models that feature open clamping arms
- Lightweight aluminum

Application Areas:

- Checking fixtures
- Areas requiring multiple clamping points

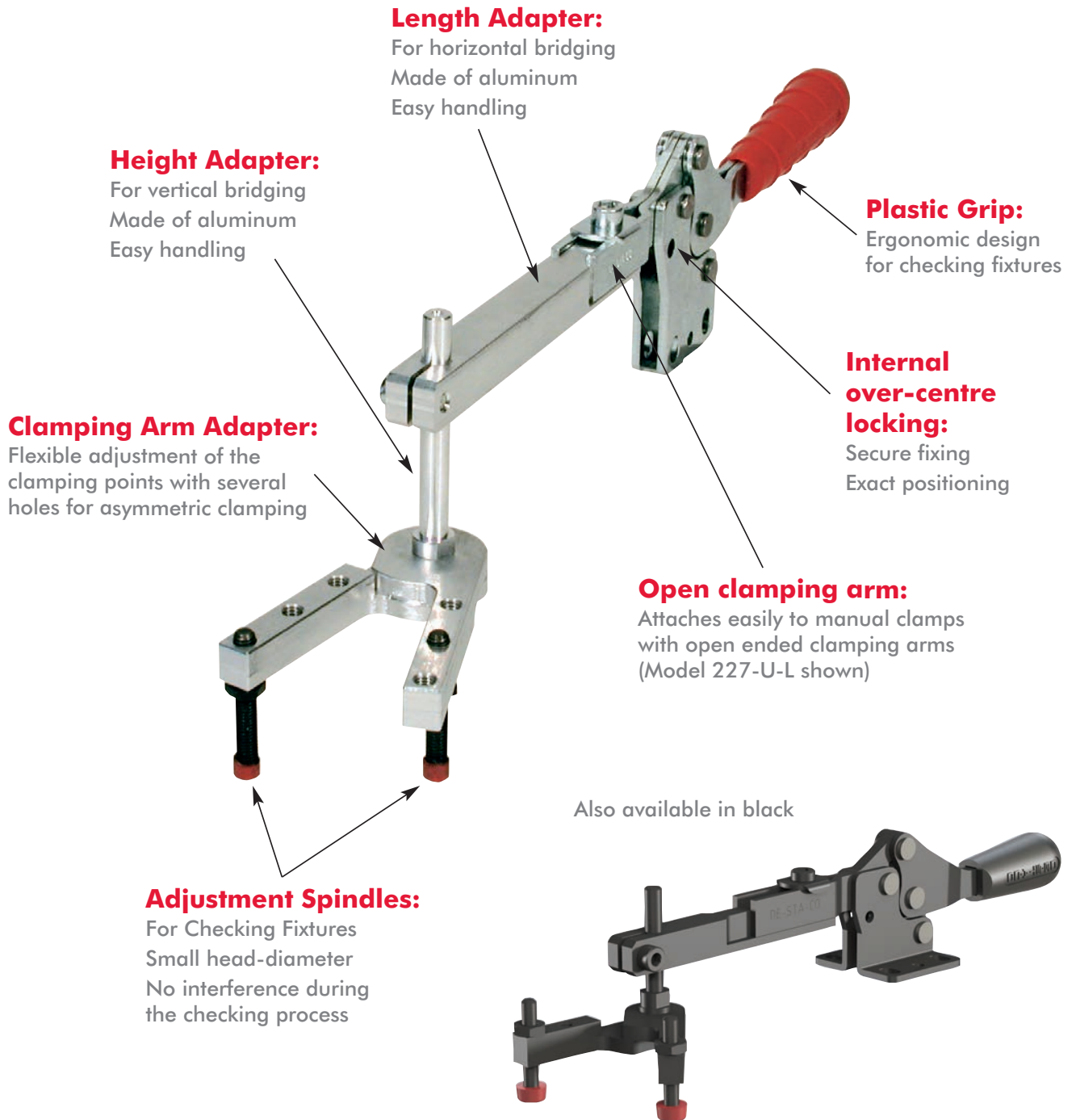

Adapters & Extensions

Length Adapter

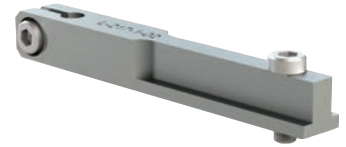
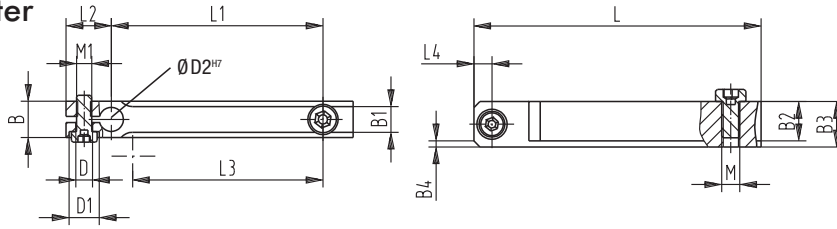

Model no.	Length adapter	B	B1 +0, -1	B2	B3	B4	DØ	D1 Ø	D2 ^{H7}	L	L1 ±0,2	L2	L3	L4	M	M1	
213-U-L / 213-UB-L 2013-U / 2013-UB 2013-UR / 2013-UBR	L-213-1-01 ⓘ L-213-1-02 ⓘ	[0.39] 10	[0.22] 5,5	[0.31] 8	[0.39] 10	2x45°	[0.22] 5,5	--		[1.97] 50 [3.54] 90	[1.18] 30 [2.76] 70	[0.47] 12	[0.79] 20	[0.20] 5	M4	M5	
202-U-L / 202-UB-L 217-U-L / 217-UB-L 2002-U-L / 2002-UB-L 2017-U / 2017-UB 2017-UR / 2017-UBR	L-217-1-01 ⓘ L-217-1-02 ⓘ L-217-1-03 ⓘ		[0.26] 6,5	[0.35] 9	[0.47] 12	2x45°	[0.22] 5,5		[0.24] 6	[2.17] 55 [3.74] 95 [5.31] 135	[1.18] 30 [2.76] 70 [4.33] 110		[1.30] 33 [1.89] 48		M5	M5	
207-U-L / 207-UB-L 227-U-L / 227-UB-L 2007-U-LS / 2007-U-LS 2027-U / 2027-UB 2027-UR / 2027-UBR	L-227-1-01 ⓘ L-227-1-02 ⓘ L-227-1-03 ⓘ L-227-1-04 ⓘ	[0.47] 12						[0.39] 10		[2.17] 55 [3.74] 95 [5.31] 135 [6.89] 175	[1.18] 30 [2.76] 70 [4.33] 110 [5.91] 150	[0.59] 15	[1.30] 33 [2.87] 73	[0.24] 6		M6	M5

ⓘ Available upon request.

Also available in Black. Add **-BLK** to part number.

Height Adapter

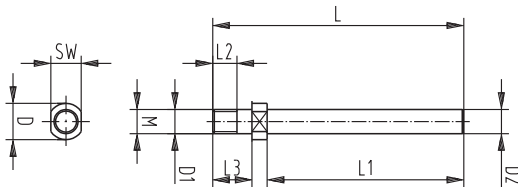

Model no.	Height adapter	DØ	D1 Ø f7	D2 f7	L	L1	L2	L3	SW	M
213-U-L / 213-UB-L 2013-U / 2013-UB 2013-UR / 2013-UBR	L-213-2-01 ⓘ L-213-2-02 ⓘ		[0.20] 5	[0.24] 6	[2.05] 52 [3.23] 82	[1.38] 35 [2.56] 65				M5
202-U-L / 202-UB-L 217-U-L / 217-UB-L 2002-U-LS / 2002-UB-LS 2017-U / 2017-UB 2017-UR / 2017-UBR	L-217-2-01 ⓘ L-217-2-02 ⓘ	[0.39] 10	[0.24] 6	[0.24] 6	[2.05] 52 [3.23] 82	[1.38] 35 [2.56] 65	[0.31] 8	[0.47] 12	[0.31] 8	M6
207-U-L / 207-UB-L 227-U-L / 227-UB-L 2007-U-LS / 2007-U-LS 2027-U / 2027-UB 2027-UR / 2027-UBR	L-227-2-01 ⓘ L-227-2-02 ⓘ	[0.31] 8	[0.31] 8	[0.31] 88	[2.09] 53 [3.23] 82	[1.38] 35 [2.56] 65		[0.51] 13	[0.39] 10	M8

ⓘ Available upon request.

Also available in Black. Add **-BLK** to part number.

Adapters & Extensions

Clamping Arm Adapter

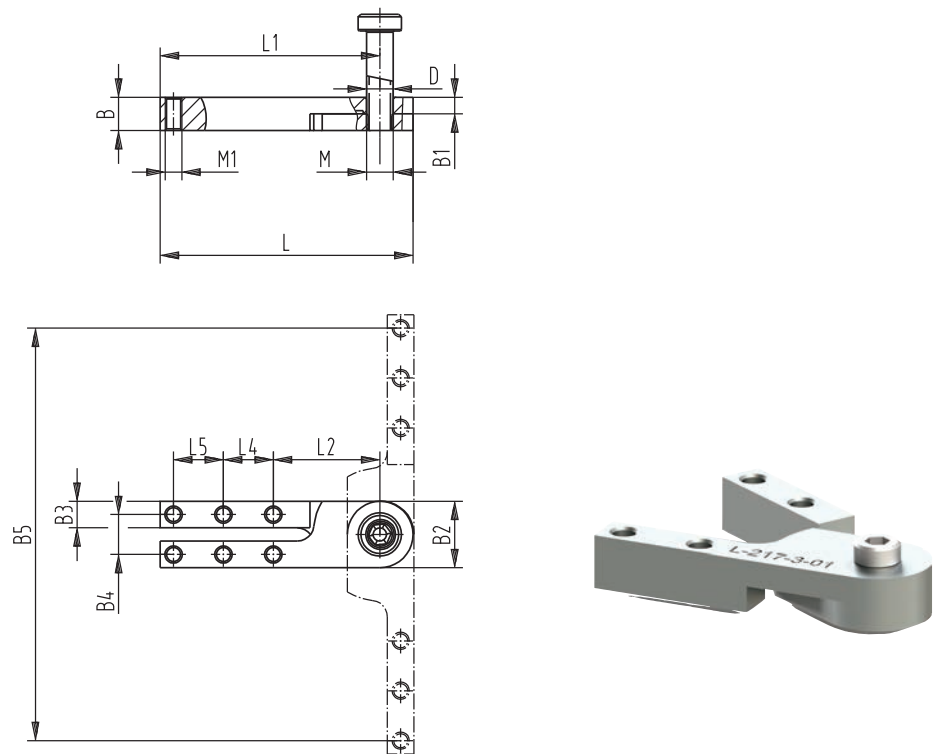

Model no.	Clamping arm adapter	B	B1	B2	B3	B4	B5	DØ _{H7}	L	L1	L2	L4	L5	L6	M	M1
213-U-L / 213-UB-L 2013-U / 2013-UB 2013-UR / 2013-UBR	L-213-3-01 ⓘ							[0.20] 5							M5	M5
202-U-L / 202-UB-L 217-U-L / 217-UB-L 2002-U-LS / 2002-UB-LS 2017-U / 2017-UB 2017-UR / 2017-UBR	L-217-3-01 ⓘ	[0.39] 10	[0.20] 5	[0.79] 20	[0.31] 8	[0.47] 12	[3.70] 94	[0.24] 6	[2.40] 61	[2.01] 51	[1.26] 32	[0.59] 15	-	[0.39] 10	M6	M5
207-U-L / 207-UB-L 227-U-L / 227-UB-L 2007-U-LS / 2007-UB-LS 2027-U / 2027-UB 2027-UR / 2027-UBR	L-227-3-01 ⓘ						4.88 124	[0.31] 8	[2.99] 76	[2.60] 66			[0.59] 15		M8	M5

ⓘ Available upon request. Also available in Black. Add **-BLK** to part number.

Adapters & Extensions

Arm Extension:

- Easily cut to length
- Drilled & tapped for spindle attachment

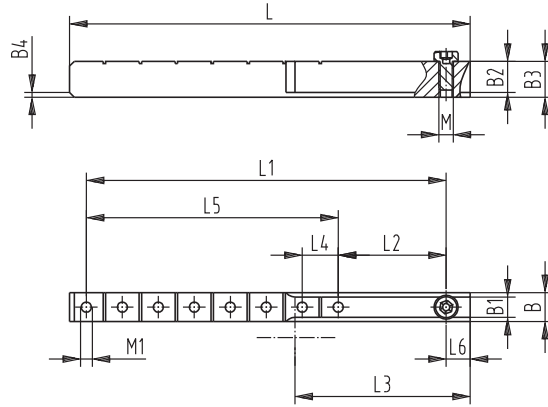

Model no.	Extension link	B	B1 +0, -1	B2	B3	B4	L ±0,2	L1	L2	L3	L4	L5	L6	M	M1
213-U-L / 213-UB-L 2013-U / 2013-UB 2013-UR / 2013-UBR	L-213-4-01	[0.39] 10	[0.22] 5,5	[0.31] 8	[0.39] 10	2x45°	[2.95] 75	[2.36] 60	[0.94] 24	[0.79] 20	[0.47] 12	[1.42] 36	[0.31] 8	M4	M5
202-U-L / 202-UB-L 217-U-L / 217-UB-L 2002-U-LS / 2002-UB-LS 2017-U / 2017-UB 2017-UR / 2017-UBR	L-217-4-01		[0.26] 6,5	[0.35] 9	[0.47] 12	2x45°	[5.00] 127	[4.33] 110	[1.38] 35	[1.89] 48		[2.95] 75	[0.39] 10	M5	M5
207-U-L / 207-UB-L 227-U-L / 227-UB-L 2007-U-LS / 2007-UB-LS 2027-U / 2027-UB 2027-UR / 2027-UBR	L-227-4-01		[0.47] 12			2x45°	[6.57] 167	[5.91] 150	[1.77] 45	[2.87] 73		[0.59] 15		M6	M5

Available upon request. Also available in Black. Add **-BLK** to part number.

Cross Arm Set

- 1 x cross arm
- 2 x adjustment spindles with neoprene thrust pads vulcanized, resin-free, inc.
- 2 x fastening nuts
- 4 x flange washers
- 1 x screw incl. 1 x fastening nut, self-locking

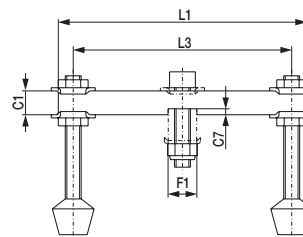

Model no.	For Models with U Arms	C1	C7	F	F1	L1	L3	Adjustable Spindles
207426-Q	207, 225, 227	[0.47] 12	[0.12] 3	[0.31] 35	[0.57] 14,5	[4.92] 125	[4.33] 110	507208-M
210440-Q	210, 235, 237	[0.63] 16	[0.16] 4	[0.43] 11	[0.75] 19	[5.87] 149	[5.12] 130	240208-M