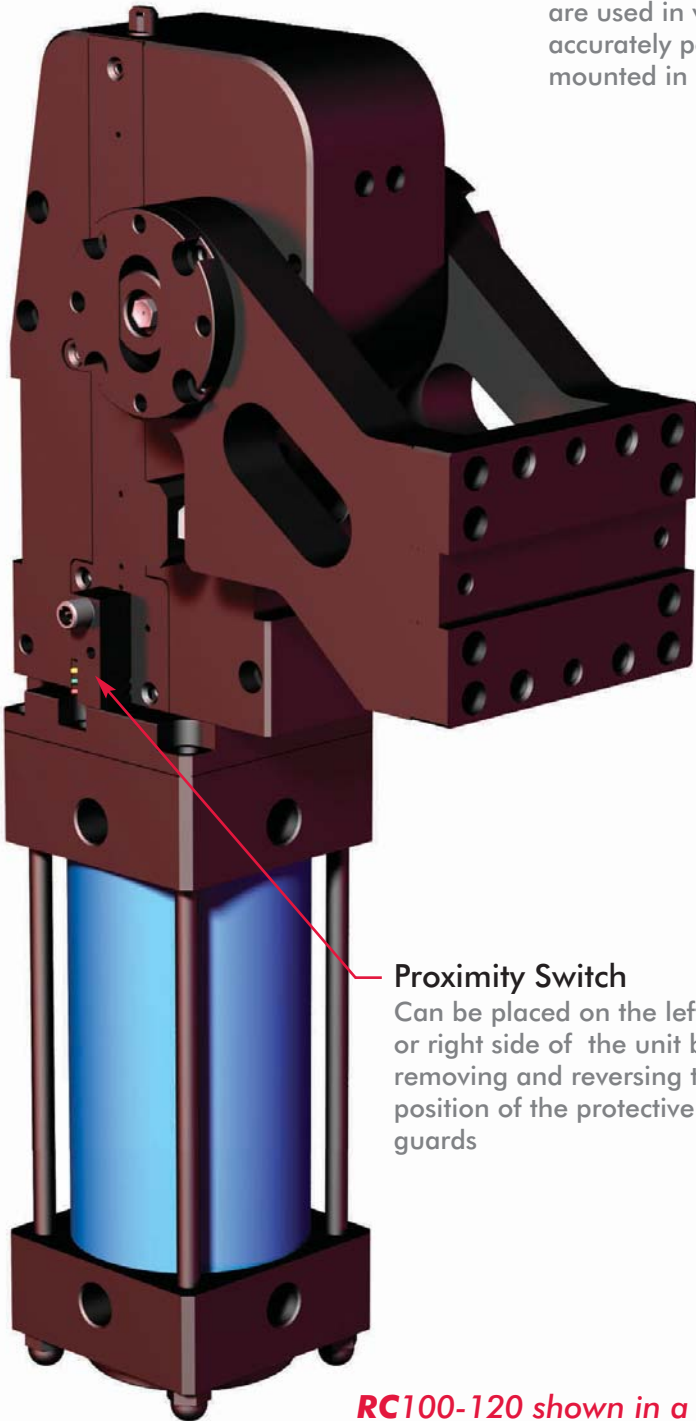

**GR and RC Series** Medium Duty Pivot Units**GR and RC Series Pneumatic Pivot Units**

are used in welding applications or anywhere it is necessary to accurately position tooling. Both the RC and GR series can be mounted in an upright vertical or horizontal position.

**Proximity Switch**

Can be placed on the left or right side of the unit by removing and reversing the position of the protective guards

**RC100-120** shown in a vertical "V" orientation

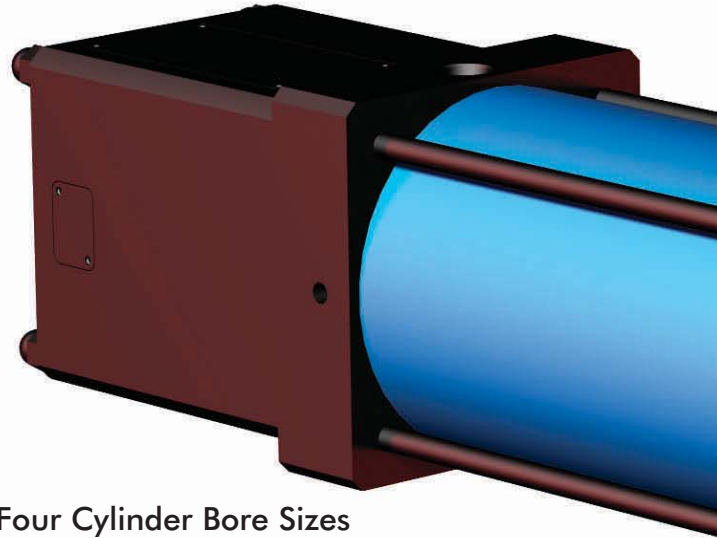
**Four Cylinder Bore Sizes**

Available in 100, 125, 160 & 200mm cylinder bore sizes. Cylinders are offered with NPT or ISO G ports

**Cut Off Valve (GR Series Only)**

Stops movement when air pressure is lost.



**GR and RC Series** Medium Duty Pivot Units

**Available in three different arm opening angles**

45°, 90° and 120° arm opening angles are available in both the horizontal and vertical mount orientation. Both mounting orientations can also be ordered with an inverted mounting bracket.

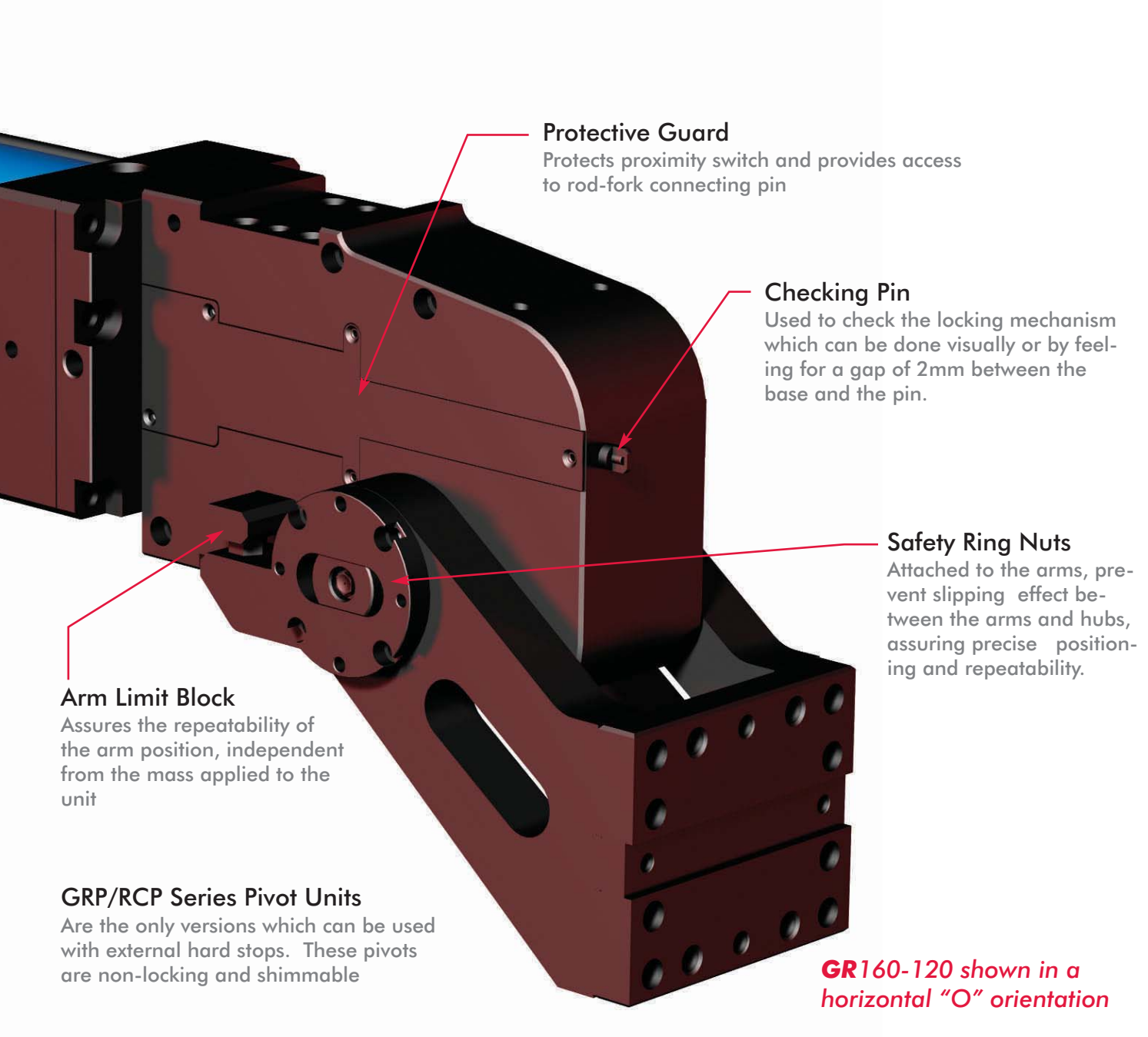

GR and RC Series Medium Duty Pivot Units

Ordering Information

**GR**

**160**

**120**

**V**

**PNEUMATIC PIVOT MODEL**

**GR** = GR SERIES PIVOT UNITS  
(HYDRAULIC MOTION CONTROL  
WITH BRAKING FEATURE)

**\*GRP** = GR SERIES PIVOT UNITS  
**NON LOCKING VERSION**  
(HYDRAULIC MOTION CONTROL  
WITH BRAKING FEATURE)

**RC** = RC SERIES PIVOT UNITS  
(HYDRAULIC MOTION CONTROL  
WITHOUT BRAKING FEATURE)

**\*RCP** = RC SERIES PIVOT UNITS  
**NON LOCKING VERSION**  
(HYDRAULIC MOTION CONTROL  
WITHOUT BRAKING FEATURE)

**CYLINDER OPTIONS**

**100** = 100MM BORE CYLINDER

**125** = 125MM BORE CYLINDER

**160** = 160MM BORE CYLINDER

**200** = 200MM BORE CYLINDER

**OPENING ANGLE**

**45** = 45°

**90** = 90°

**120** = 120°

**ORIENTATION**

**O** = HORIZONTAL

**V** = VERTICAL

**O/LS** = INVERTED HORIZONTAL

**V/LS** = INVERTED VERTICAL

**\*ONLY RCP AND GRP PIVOT UNITS  
CAN BE USED WITH EXTERNAL HARD  
STOPS AND SHIMMING**



GR and RC Series Medium Duty Pivot Units

Ordering Information

**PX**

**0**

**N**

**X**

**CYLINDER POSITION**  
(SEE BELOW)

- X** = CYLINDER POSITION X
- Y** = CYLINDER POSITION Y
- W** = CYLINDER POSITION W
- Z** = CYLINDER POSITION Z

**PORT TYPE**

- N** = NPT PORTS
- G** = G PORT

**PROXIMITY SWITCH TYPE**

- 0** = NO PROXIMITY SWITCH
- T** = TURCK PROXIMITY SWITCH
- P** = PEPPERL+FUCHS PROXIMITY SWITCH
- PM** = PEPPERL+FUCHS PROXIMITY SWITCH (WHITE LED)

**PROXIMITY SWITCH LOCATION (SEE BELOW)**

- P0** = NO PROXIMITY SWITCH
- PX** = PROXIMITY SWITCH ON THE X SIDE
- PY** = PROXIMITY SWITCH ON THE Y SIDE

GR & RC Series Optional Cylinder Position (See page 9 for port sizes and locations)

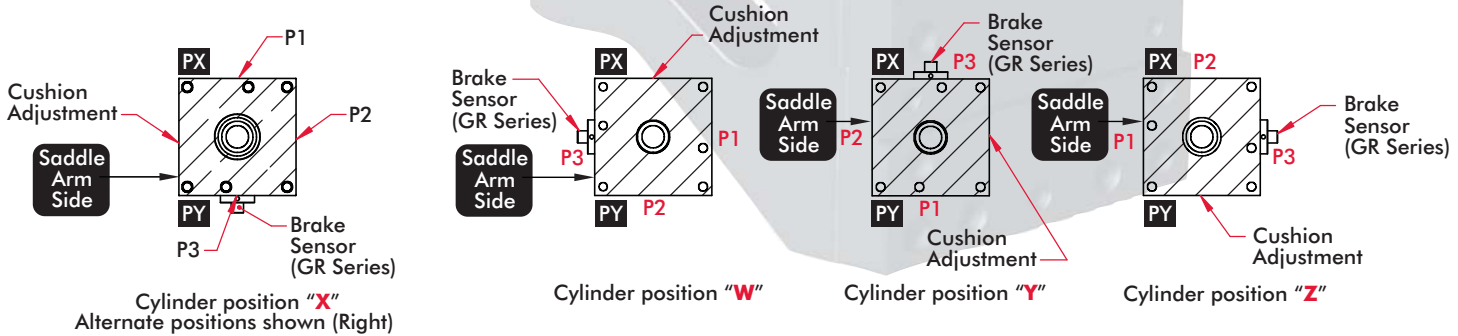

GR and RC Series Medium Duty Pivot Units

GR-RC 100 Vertical Orientation Pivot Dimensions

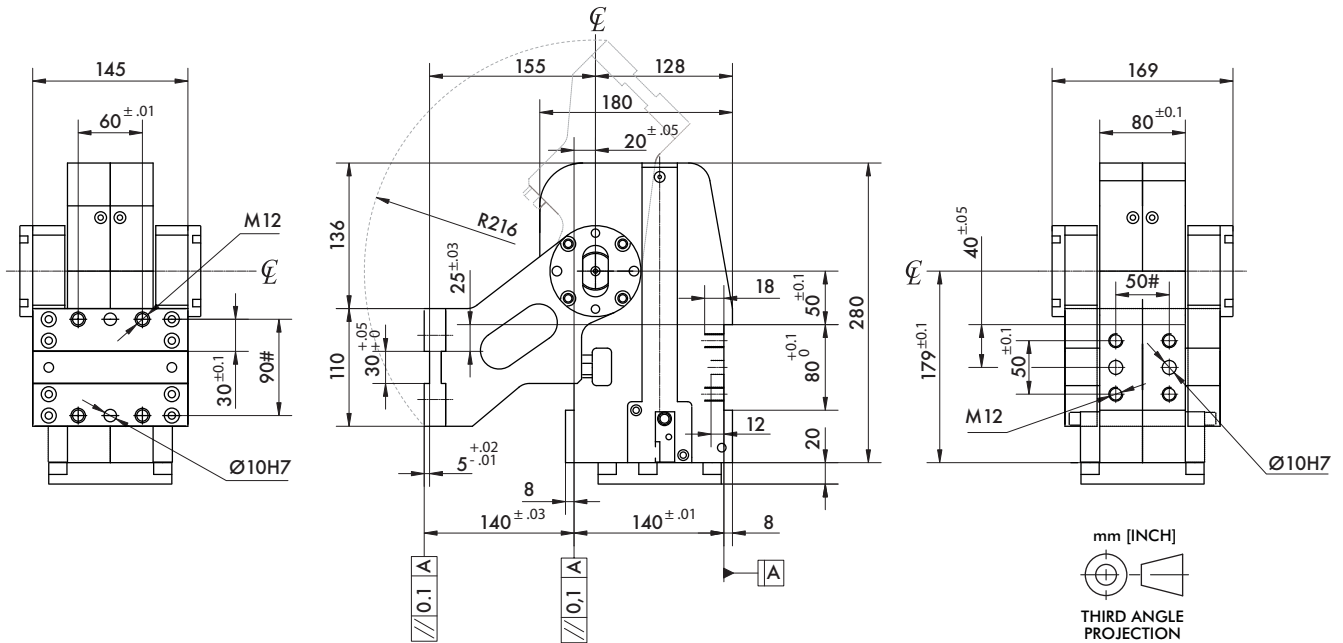

GR-RC 100 Horizontal Orientation Pivot Dimensions

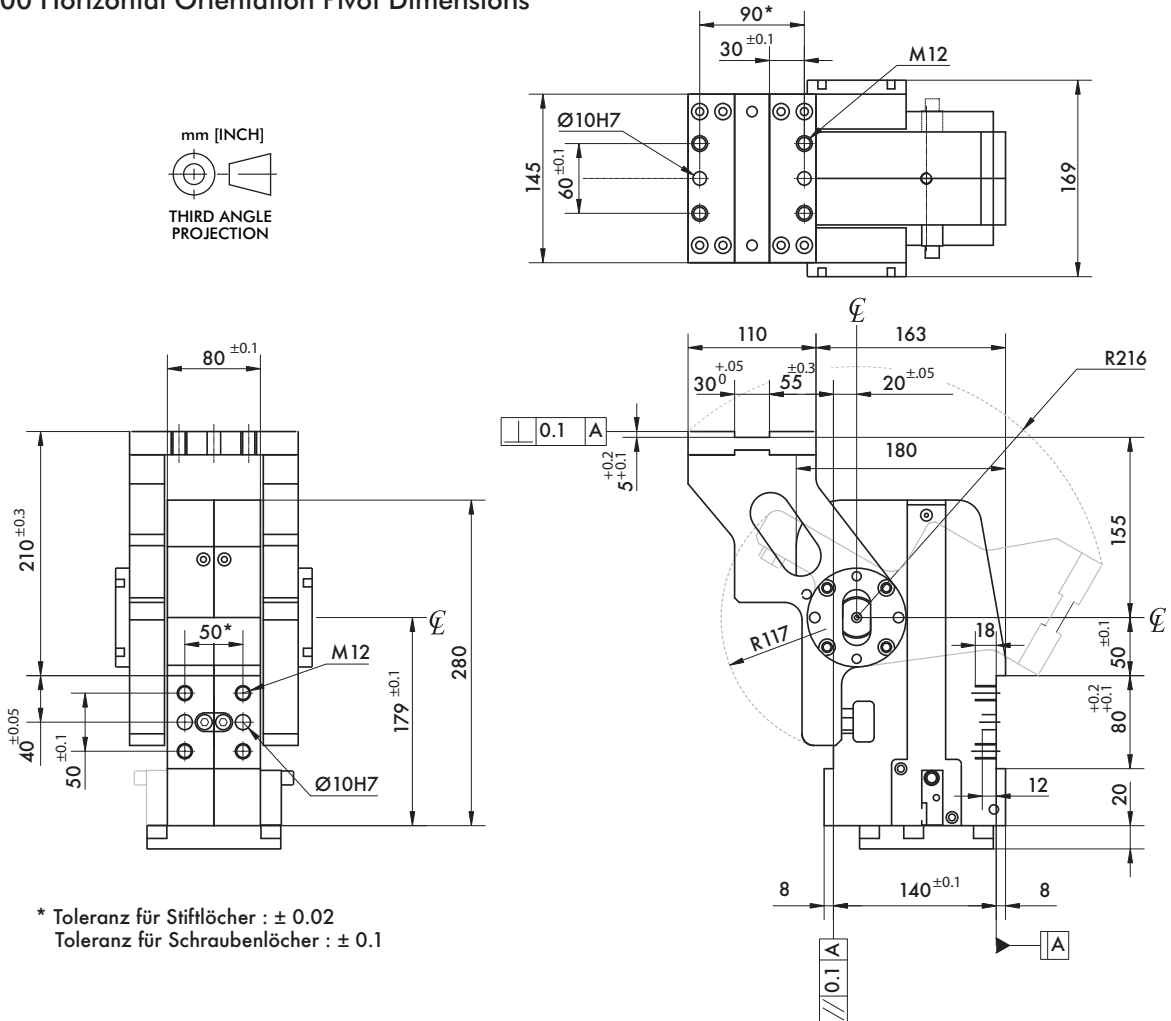

\* Toleranz für Stiftlöcher : ± 0.02  
Toleranz für Schraubenlöcher : ± 0.1

GR and RC Series Medium Duty Pivot Units

GR-RC 125-160-200 Vertical Orientation Pivot Dimensions

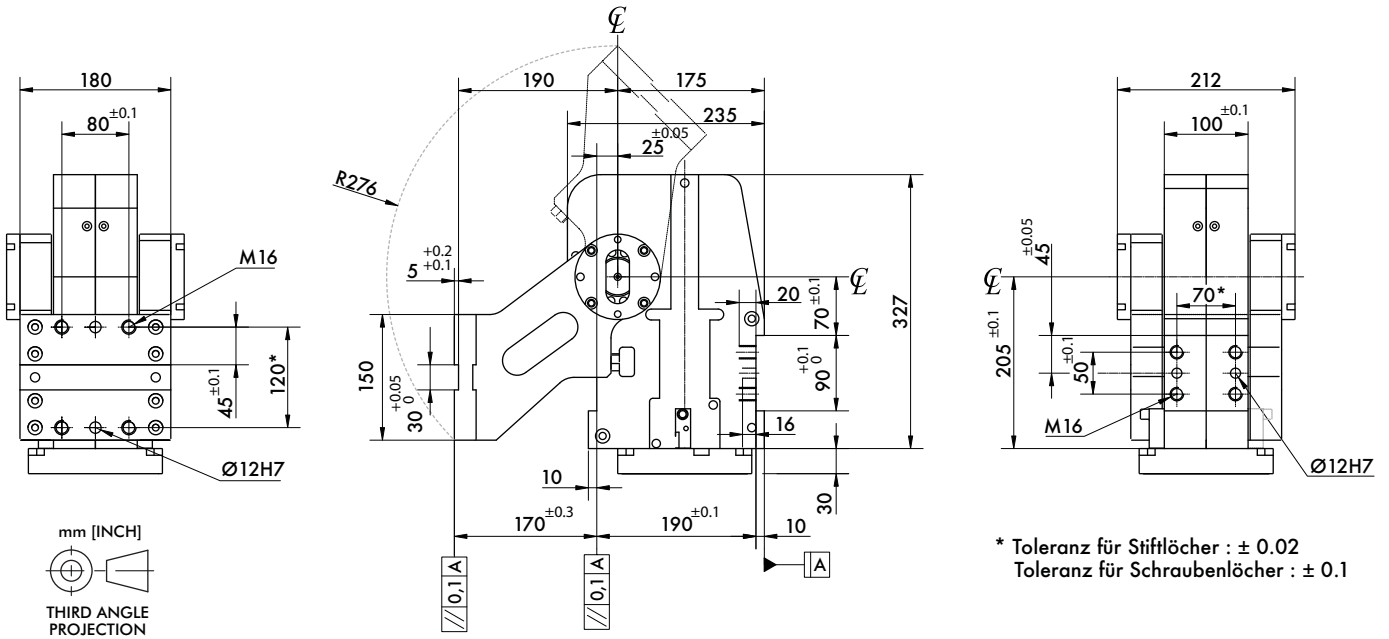

GR-RC 125-160-200 Horizontal Orientation Pivot Dimensions

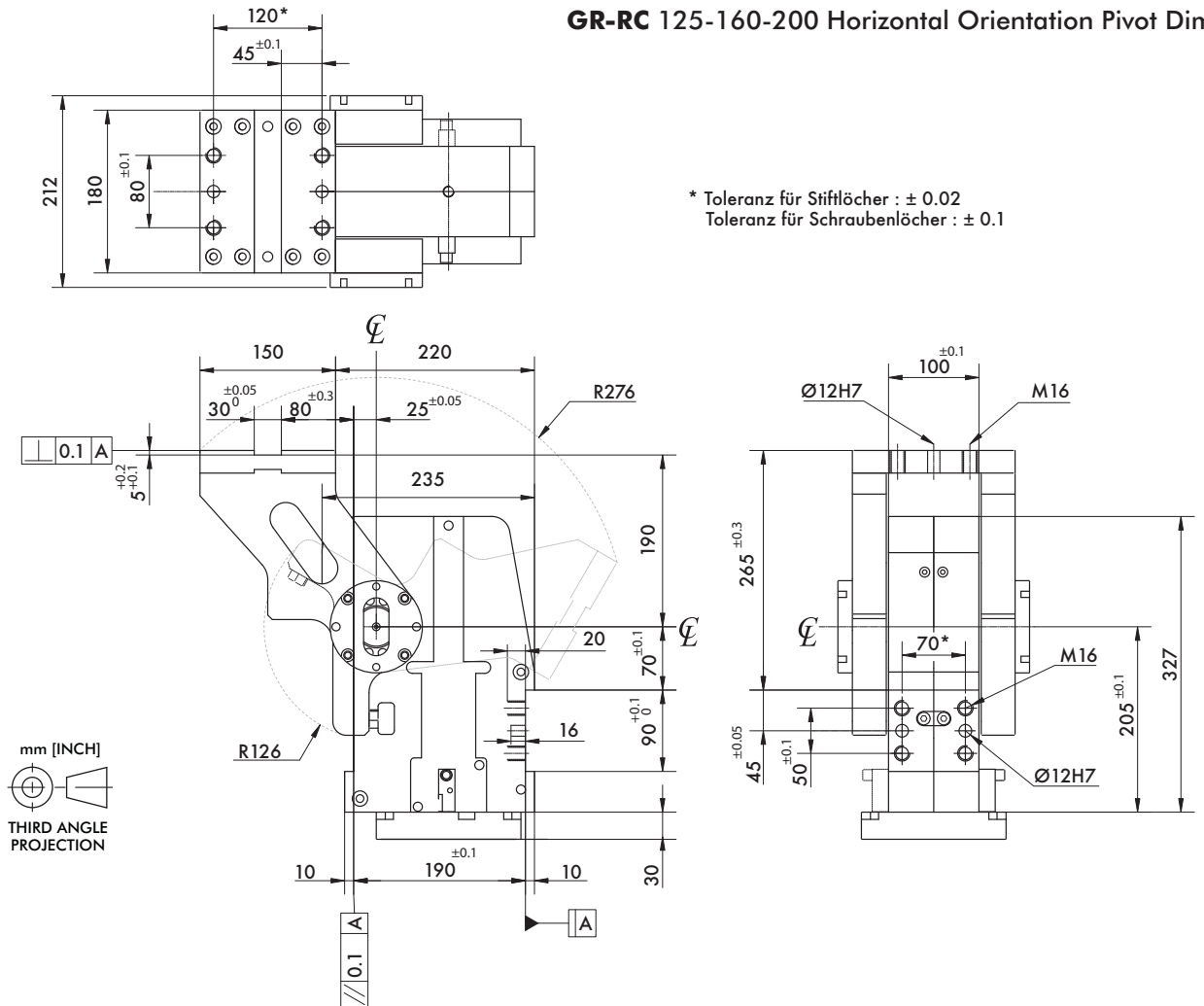

**GR and RC Series Medium Duty Pivot Units Movement**

**Arm Opening Angle and Saddle Movement**

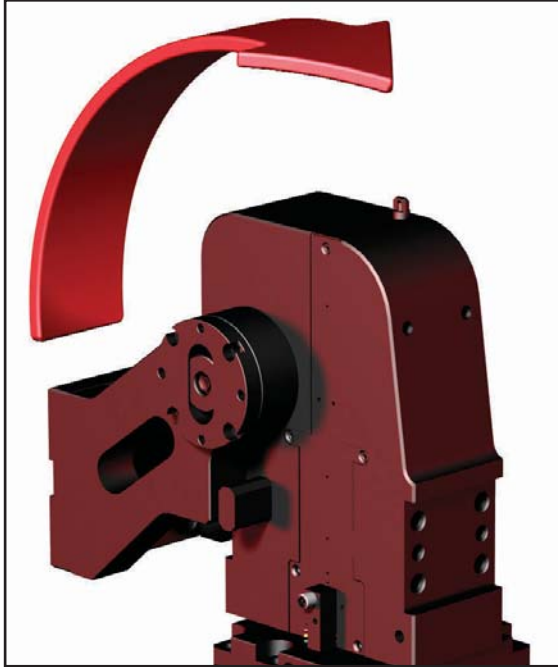

**Vertical Saddle Orientation**

Arm opening angles offered:

- 45° Arm Opening Angle
- 90° Arm Opening Angle
- 120° Arm Opening Angle

Swivel Arm Position

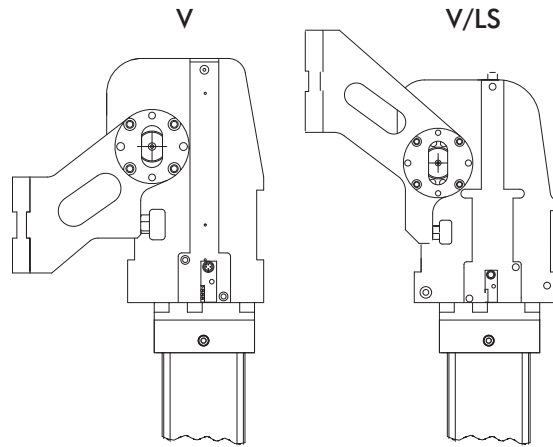

**Horizontal Saddle Orientation**

Arm opening angles offered:

- 45° Arm Opening Angle
- 90° Arm Opening Angle
- 120° Arm Opening Angle

Swivel Arm Position

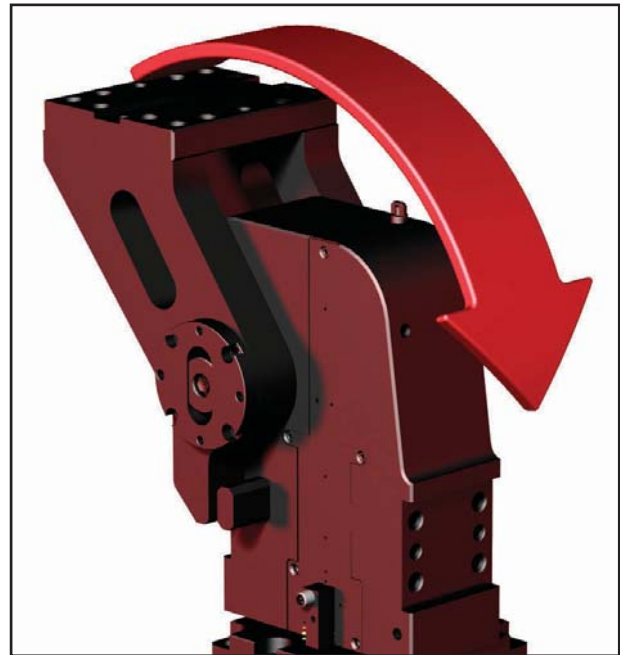
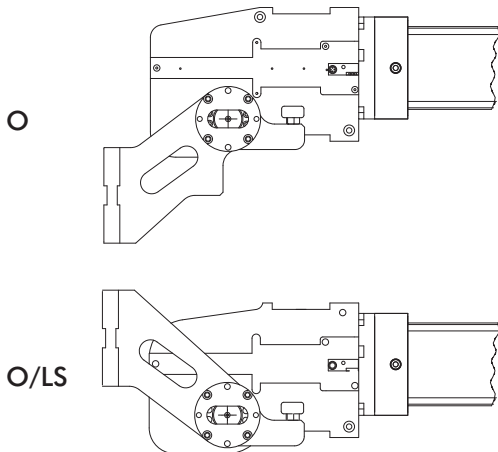

GR and RC Series Medium Duty Pivot Units Dimensions

Type "LS" Vertical Orientation Dimensions

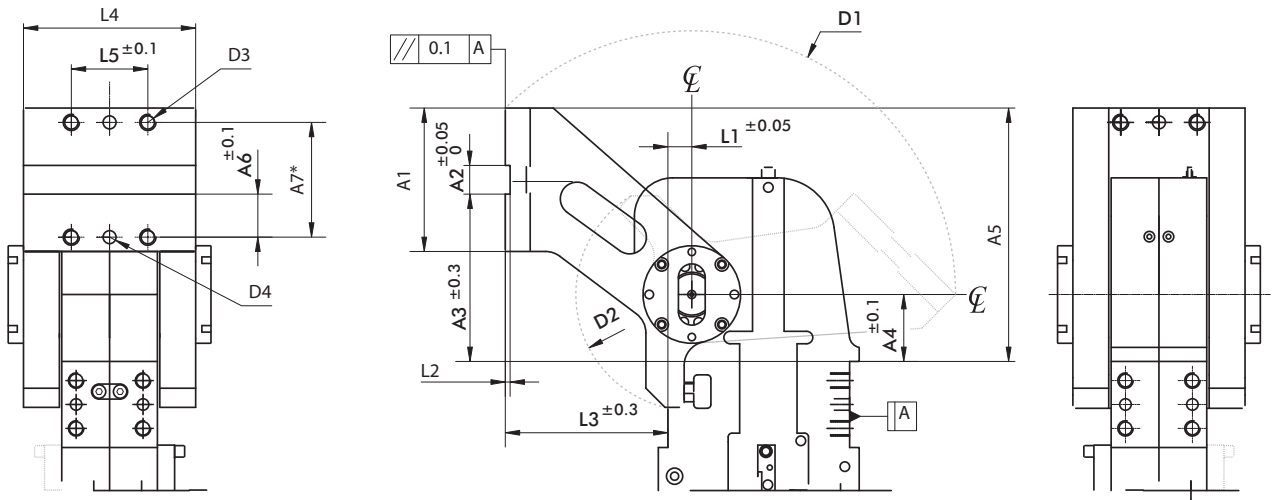

MODEL	A1	A2	A3	A4	A5	A6	A7	L1	L2	L3	L4	L5	D1	D2	D3	D4	H7	Max. opening angle
	mm																	
GR/RC100-...V/LS	110	30	125	50	195	30	90	20	5	140	145	60	216	117	M12	Ø10		120°
GR/RC125-...V/LS																		
GR/RC160-...V/LS	150	30	175	70	265	45	120	25	5	170	180	80	276	126	M16	Ø12		
GR/RC200-...V/LS																		

Type "LS" Horizontal Orientation Dimensions

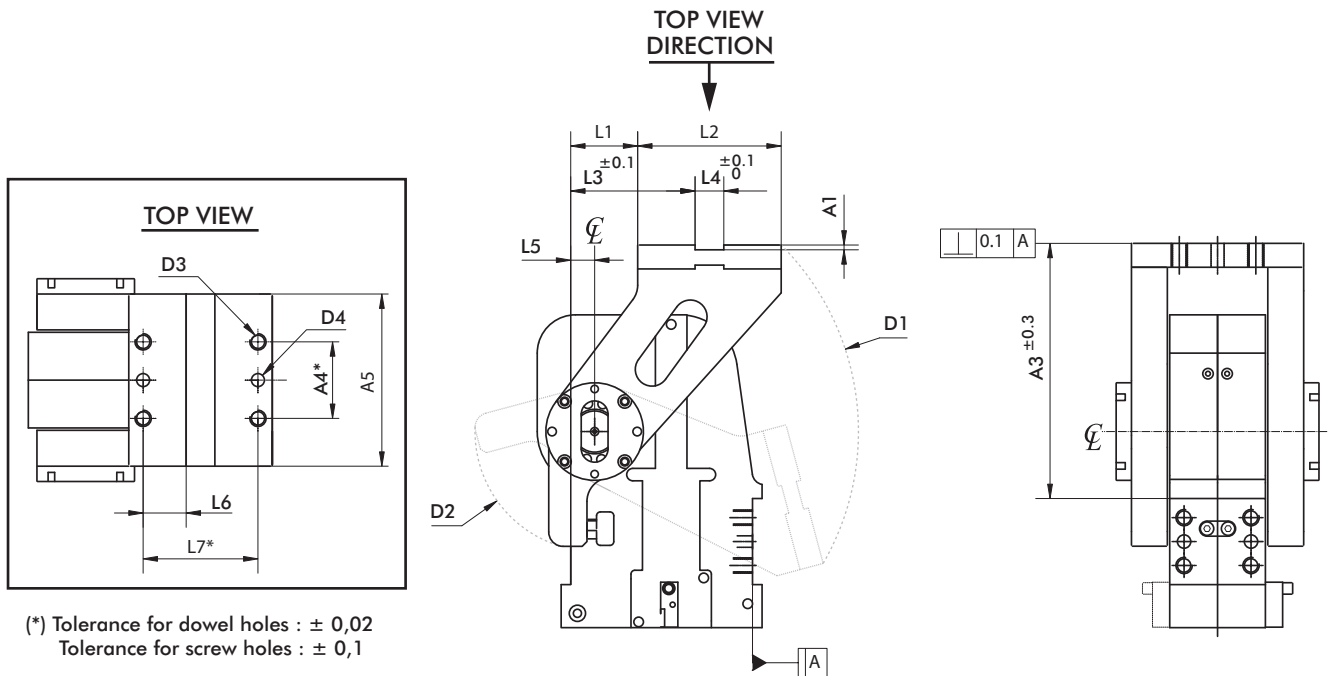

MODEL	A1	A2	A3	A4	A5	L1	L2	L3	L4	L5	L6	L7	D1	D2	D3	D4	H7	Max. opening angle
	mm																	
GR/RC100-...O/LS	5	50	210	60	145	55	110	95	30	20	30	90	216	117	M12	Ø10		90°
GR/RC125-...O/LS																		
GR/RC160-...O/LS	5	70	265	80	180	70	150	130	30	25	45	120	276	126	M16	Ø12		80°
GR/RC200-...O/LS																		

GR and RC Series Medium Duty Pivot Units

GR Series Cylinder Dimensions

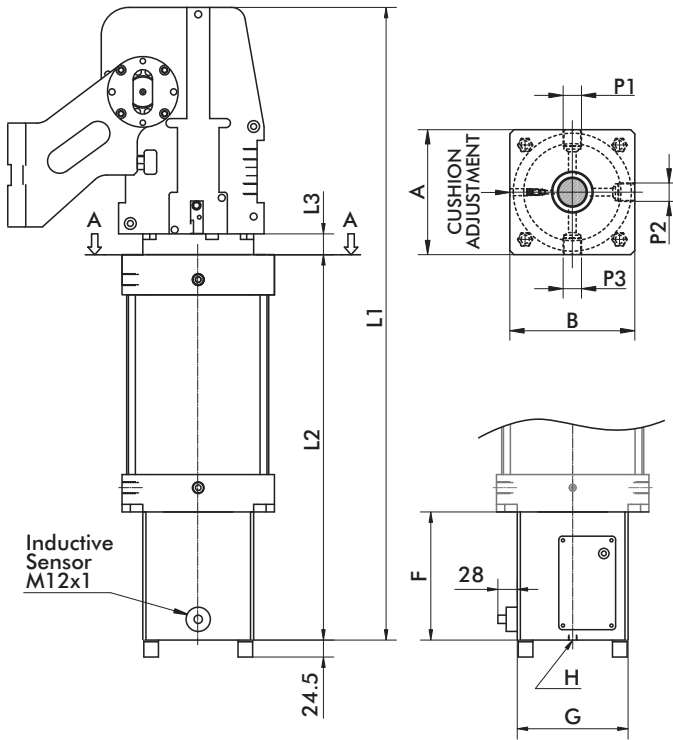

GR MODEL	L1	L2	L3	A-B	P3	P1 - P2	Weight
	mm						
GR100-45°	683.5	383.5					
GR100-90°	728.5	428.5	20	115	1/2" G	1/2" G or 1/2" NPT	36 kg [80 lb]
GR100-120°	758.0	458.0					
GR125-45°	818.0	466.0					
GR125-90°	867.0	515.0	25	160	1/2" G	1/2" G or 1/2" NPT	80 kg [176 lb]
GR125-120°	895.0	543.0					
GR160-45°	827.0	472.0					
GR160-90°	876.0	521.0	28	180	3/4" G	3/4" G or 3/4" NPT	95 kg [209 lb]
GR160-120°	804.0	547.0					
GR200-45°	835.0	478.0					
GR200-90°	884.0	527.0	30	220	3/4" G	3/4" G or 3/4" NPT	103 kg [226 lb]
GR200-120°	912.0	555.0					

NOTE: "P1-P2" DEPENDANT ON ORDERING CODE

GR MODEL	F	G	H
	mm		
GR100	136	115 SQ	1/4"
GR125	185	160 SQ	1/4"
GR160	185	160 SQ	1/4"
GR200	185	160 SQ	1/4"

RC Series Cylinder Dimensions

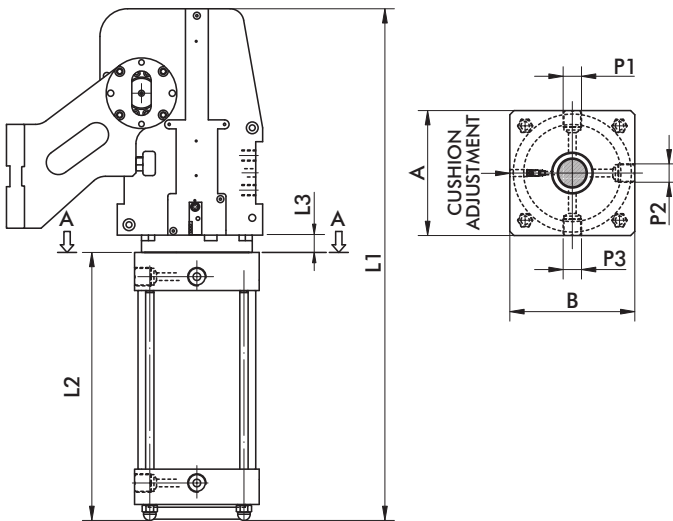

RC MODEL	L1	L2	L3	A-B	P3	P1 - P2	Weight
	mm						
RC100-45°	566.5	266.5					
RC100-90°	611.5	311.5	20	115	1/2" G	1/2" G or 1/2" NPT	29 kg [64 lb]
RC100-120°	641.0	341.0					
RC125-45°	656.0	304.0					
RC125-90°	705.0	353.0	25	160	1/2" G	1/2" G or 1/2" NPT	62 kg [137 lb]
RC125-120°	733.0	381.0					
RC160-45°	665.0	310.0					
RC160-90°	714.0	359.0	28	180	3/4" G	3/4" G or 3/4" NPT	77 kg [170 lb]
RC160-120°	742.0	387.0					
RC200-45°	670.0	313.0					
RC200-90°	719.0	362.0	30	220	3/4" G	3/4" G or 3/4" NPT	85 kg [187 lb]
RC200-120°	746.5	389.5					

NOTE: "P1-P2" DEPENDANT ON ORDERING CODE

GR & RC Series Optional Cylinder Orientation

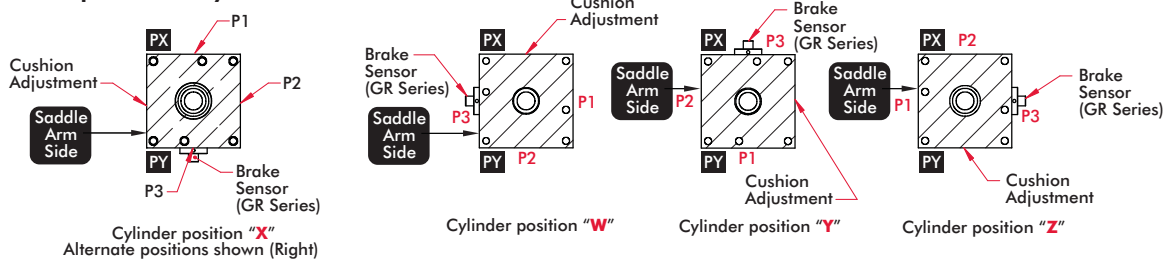



GR and RC Series Medium Duty Pivot Units

Maximum Torque for Weight

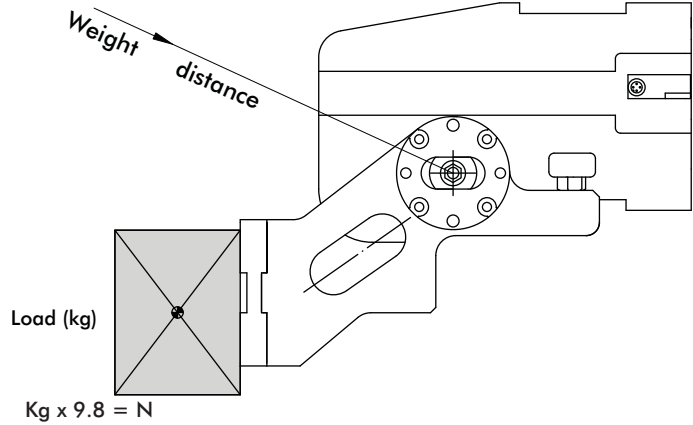
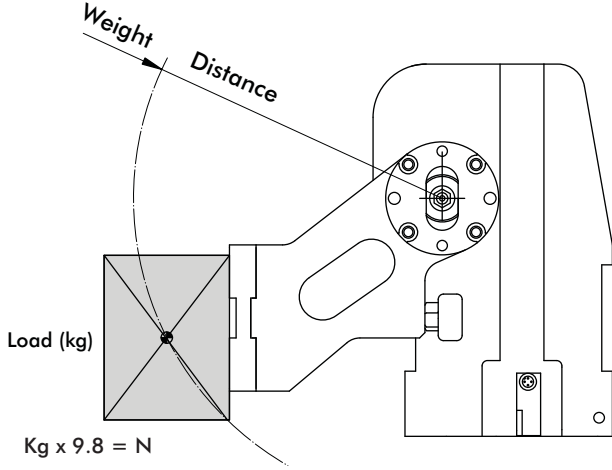

Model	Maximum Torque for Weight - ≤ 90° opening					
	58psi / 4 Bar		72psi / 5 Bar		87psi / 6 Bar	
	lbf*in	N*m	lbf*in	N*m	lbf*in	N*m
GR/RC100	1062	120	1328	150	1682	190
GR/RC125	1563	180	2124	240	2567	290
GR/RC160	2832	320	3629	410	4425	500
GR/RC200	4514	510	5841	660	7081	800

Model	Maximum Torque for Weight - > 90° opening					
	58psi / 4 Bar		72psi / 5 Bar		87psi / 6 Bar	
	lbf*in	N*m	lbf*in	N*m	lbf*in	N*m
GR/RC100	620	70	797	90	1062	120
GR/RC125	1239	140	1593	180	2036	230
GR/RC160	2124	240	2744	310	3540	400
GR/RC200	3629	410	4602	520	5488	620

Model	Maximum Torque with Side Load for Weight					
	58psi / 4 Bar		72psi / 5 Bar		87psi / 6 Bar	
	lbf*in	N*m	lbf*in	N*m	lbf*in	N*m
GR/RC100	708	80	708	80	708	80
GR/RC125	1770	200	1770	200	1770	200
GR/RC160	1770	200	1770	200	1770	200
GR/RC200	1770	200	1770	200	1770	200

Center of Gravity to Pivot (distance in Meters [Inches]) X Tooling Weight (N [lb] = Torque for weight (N\*m [lbf\*in])  
 Distance from Center of Gravity to pivot is measured parallel to the floor

**Notes**

The total torque for the application must be less than the Maximum Torque for a given pressure in the Maximum Torque for Weight charts above. For applications with a total torque greater than the Maximum Torque shown, please see RU Series Pivot Units.

Based on cycle time of 7-8 seconds. Flow controls must be used to provide this cycle time. Cushions must also be adjusted to provide deceleration to the load. Failure to control movement will severely damage unit and cause premature failure.

Use the following graphs to determine the maximum amount of tooling weight that is allowed. The tooling load should be placed as close to the center line of the unit as possible.

GR and RC Series Medium Duty Pivot Units

Maximum Added Tooling Weight less than 90°

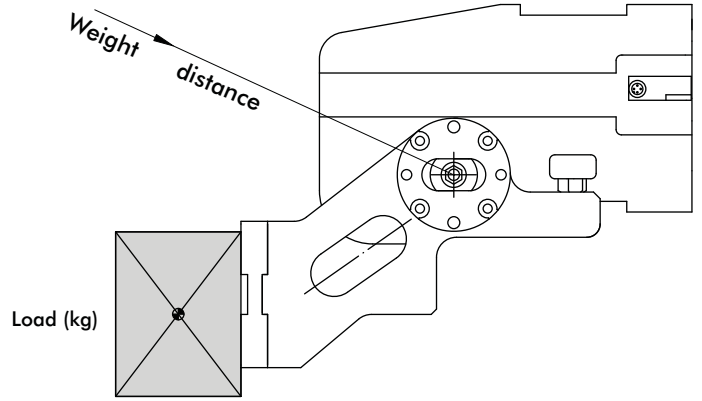
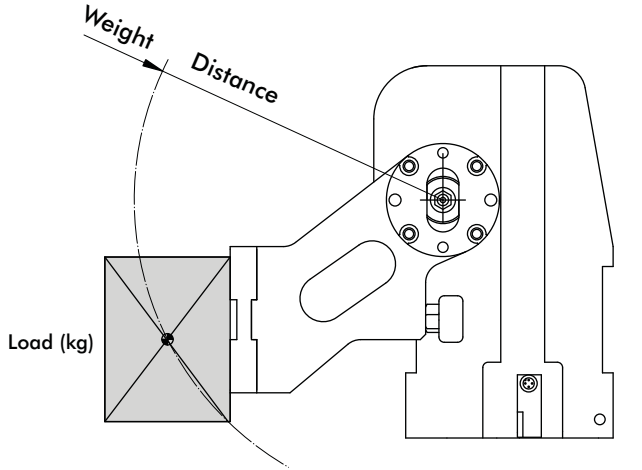

GR/RC 100

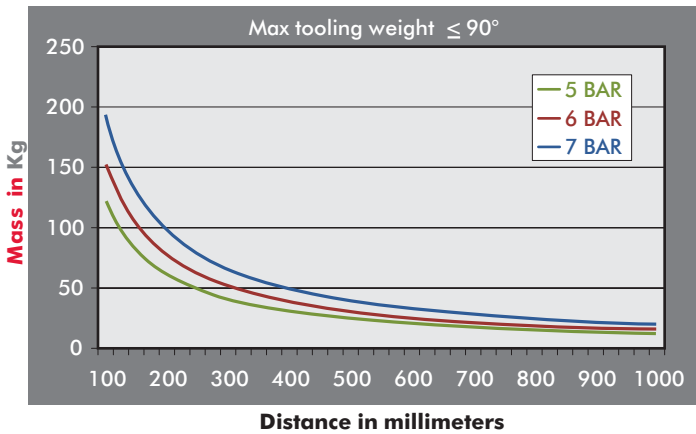

GR/RC 125

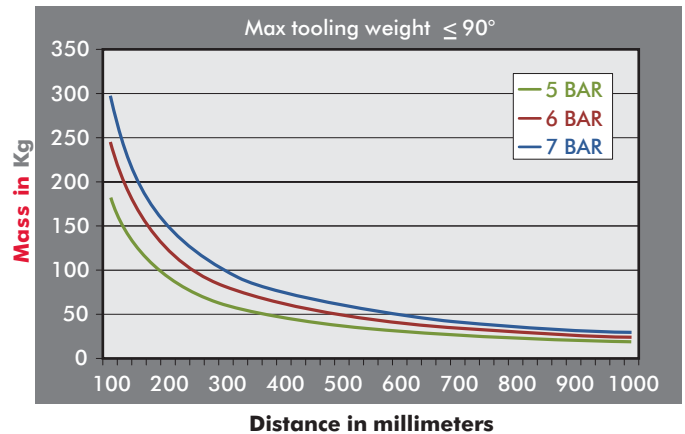

GR/RC 160

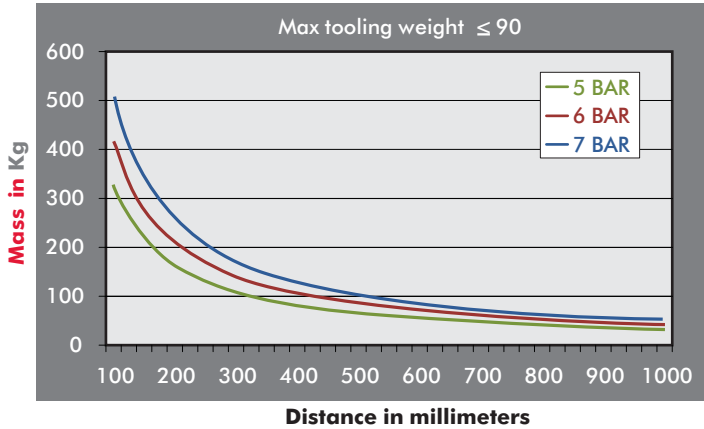

GR/RC 200

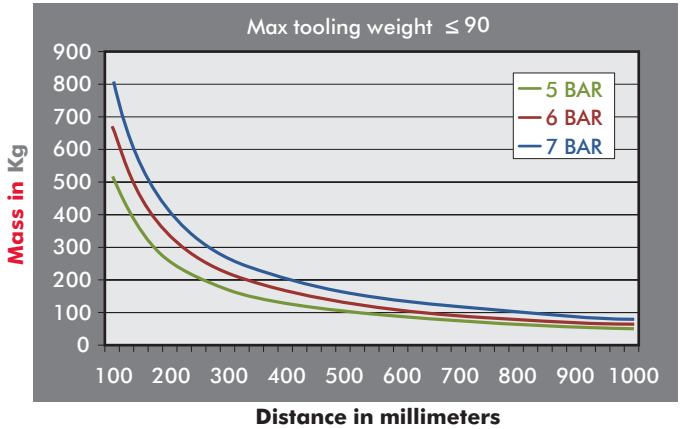

GR and RC Series Medium Duty Pivot Units

Maximum Added Tooling Weight Greater than 90°

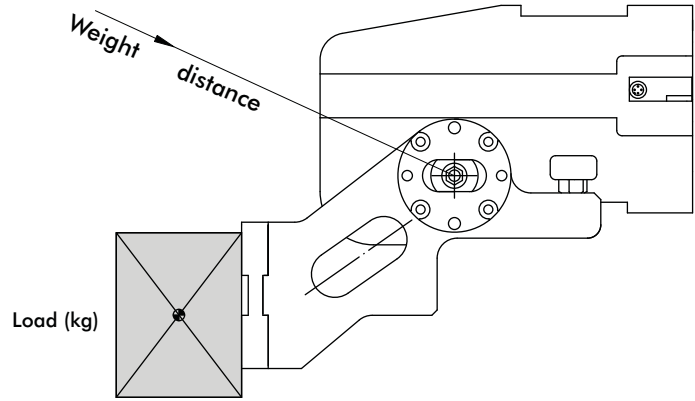
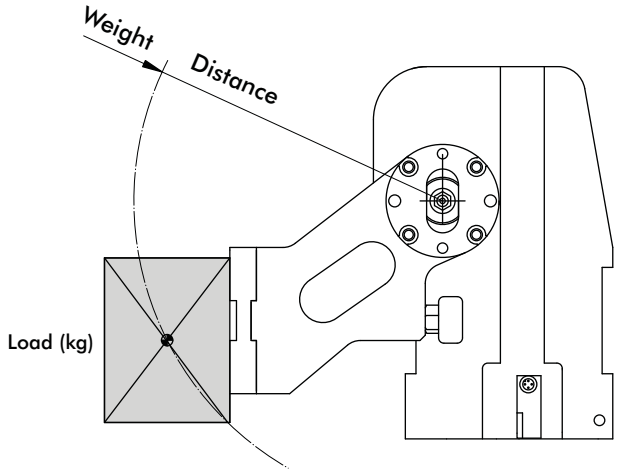

GR/RC 100

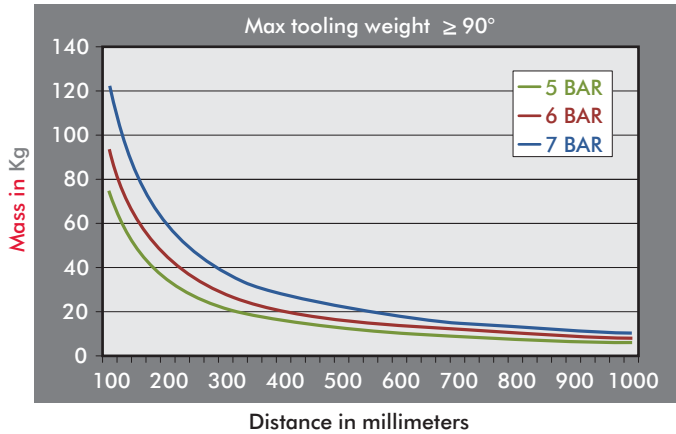

GR/RC 125

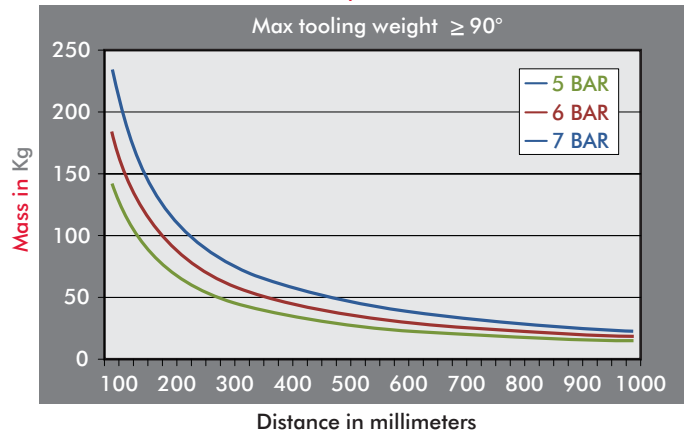

GR/RC 160

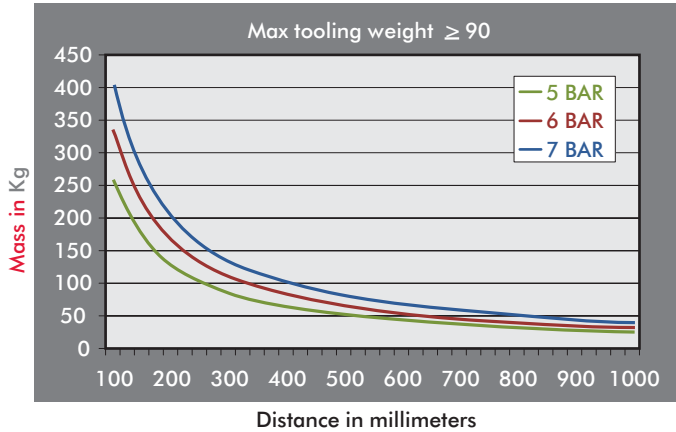

GR/RC 200

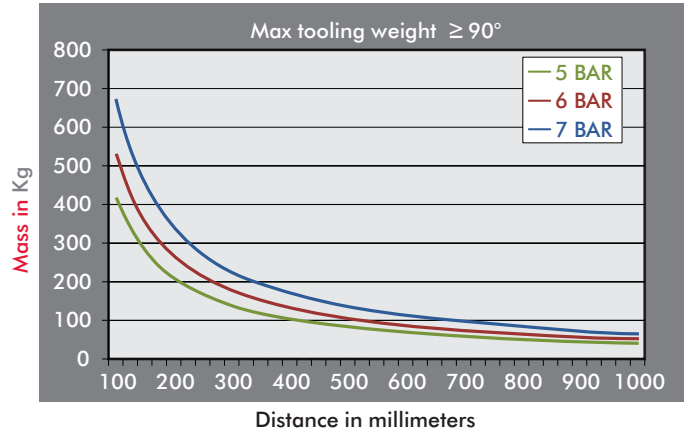



GR and RC Series Medium Duty Pivot Units

Force Charts for Opening Angles

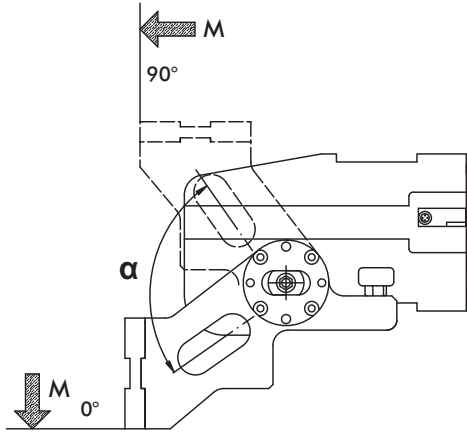

( Values calculated at 1 m from center of rotation )

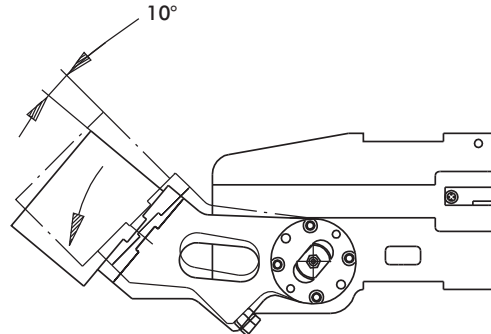

Play of swing arm while closed emergency stop value

Conditions:

- Emergency stop in operation
- Cylinder depressurized
- Max. load

Max. play 10°

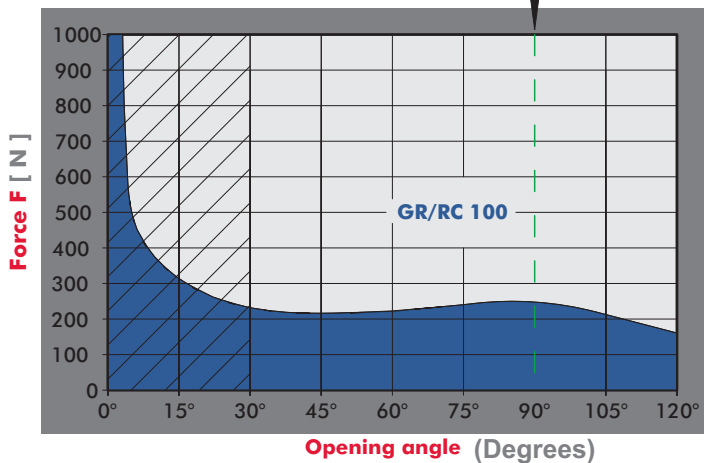

MODEL	TORQUE WITH ARM AT 90°
GR/RC 100	240 Nm
GR/RC 125	370 Nm
GR/RC 160	630 Nm
GR/RC 200	1000 Nm

NOTE: Values at 6 bar

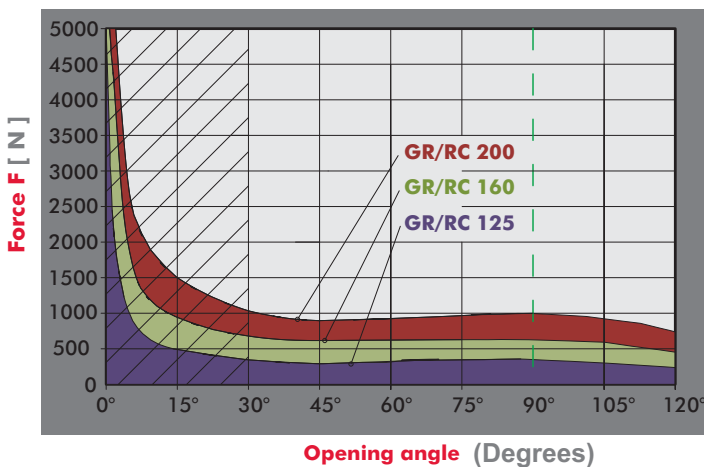

**WARNING:** Make sure that the tilting device runs a complete working cycle and reaches the angle position at 0°. (Any interference in the highlighted angle area may seriously damage both the tooling and the tilting device, as the result of the very high forces developed, as shown in the chart).

**Do not use external stops with GR/RC Series Pivot Units!**

## RU Series Heavy Duty Pivot Units

### Features and Benefits

**RU Series Pivot Units** are toggle-locking pivot units which can be used in horizontal, vertical, or side mounted applications

### Hydraulic-Pneumatic Cylinder System

Operates in the same manner as a typical cylinder. The piston rod in the cylinder, however, utilizes a hydraulic rod system which provides smooth operation throughout the stroke of the cylinder.

### Front, back, and side mounting surfaces

Offers the option of mounting the RU Pivot in the front or back so that you can use the pivot unit as a tip or dump unit. The RU Series pivot unit can also be mounted on its side as shown and can be used as a rotate unit.

### Three different cylinder bore sizes

Available in 125, 160 & 200mm cylinder bore sizes. Cylinders are offered with NPT ports

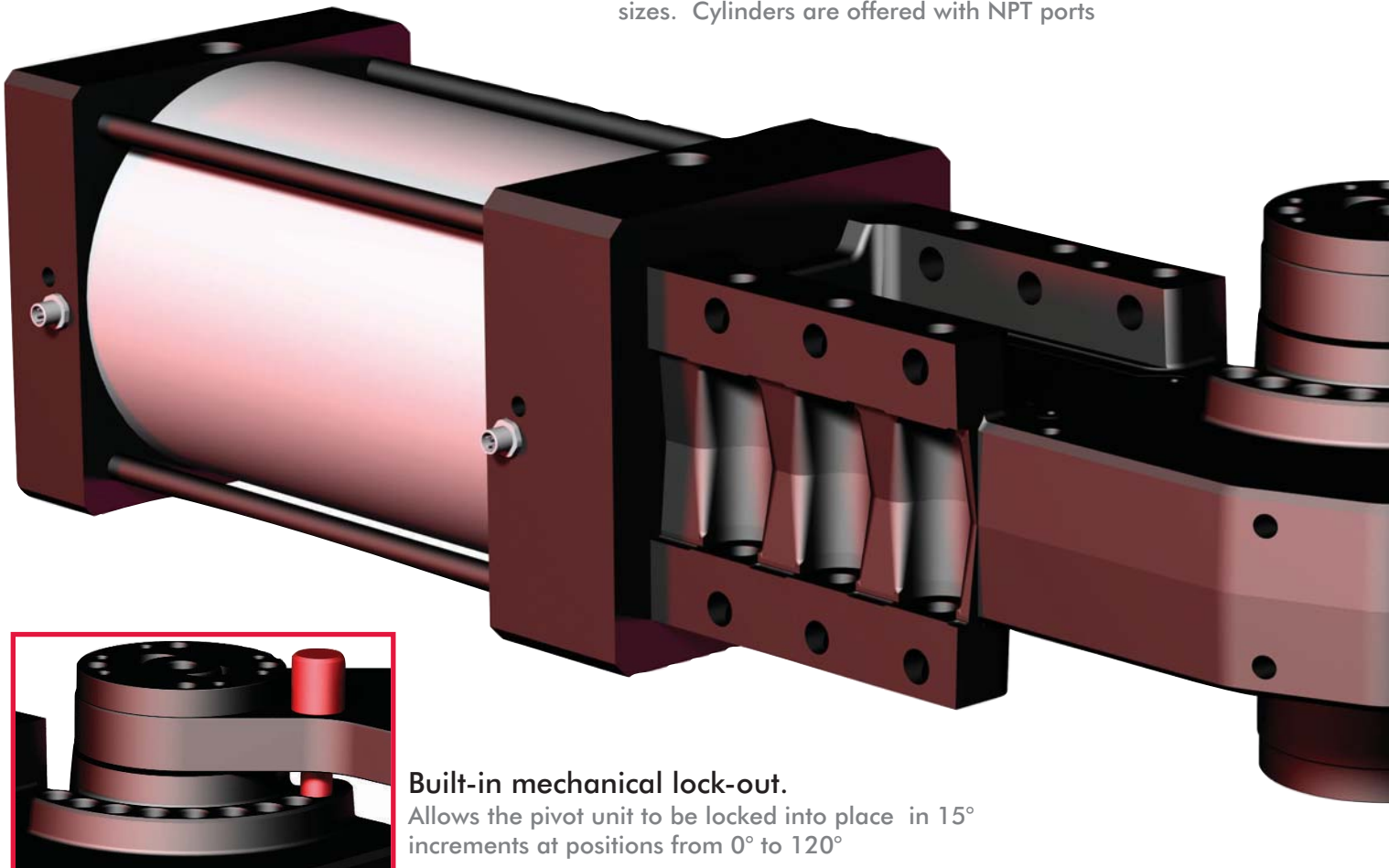

### Built-in mechanical lock-out.

Allows the pivot unit to be locked into place in 15° increments at positions from 0° to 120°

**RU Series** Medium Duty Pivot Units

## Features and Benefits

**Eight arm opening angles**

Available in 15° increments starting from 15° up to 120°, depending on the saddle arm mount starting position.

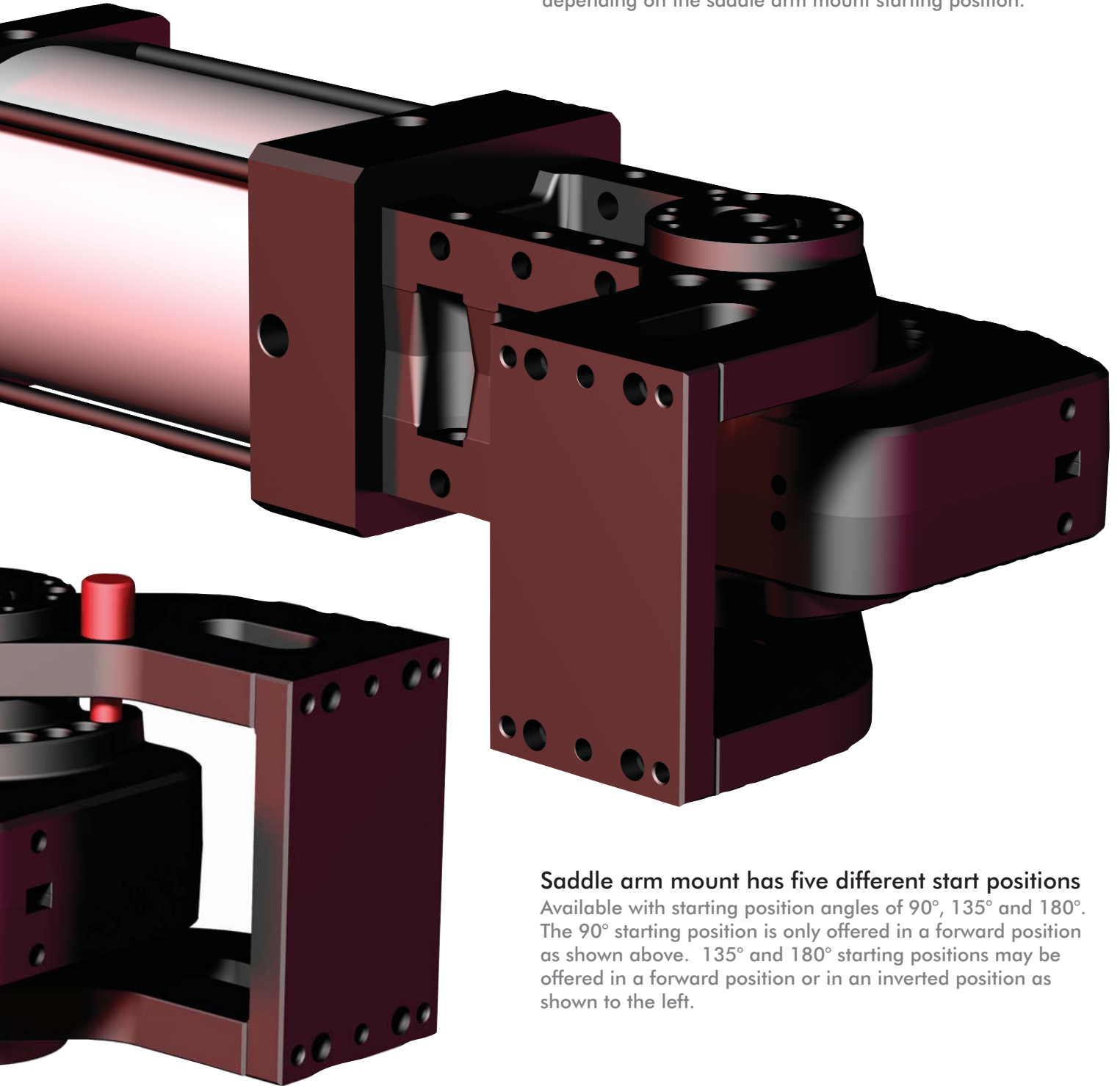
**Saddle arm mount has five different start positions**

Available with starting position angles of 90°, 135° and 180°. The 90° starting position is only offered in a forward position as shown above. 135° and 180° starting positions may be offered in a forward position or in an inverted position as shown to the left.

**RU Series** Heavy Duty Pivot Units

## Ordering Information

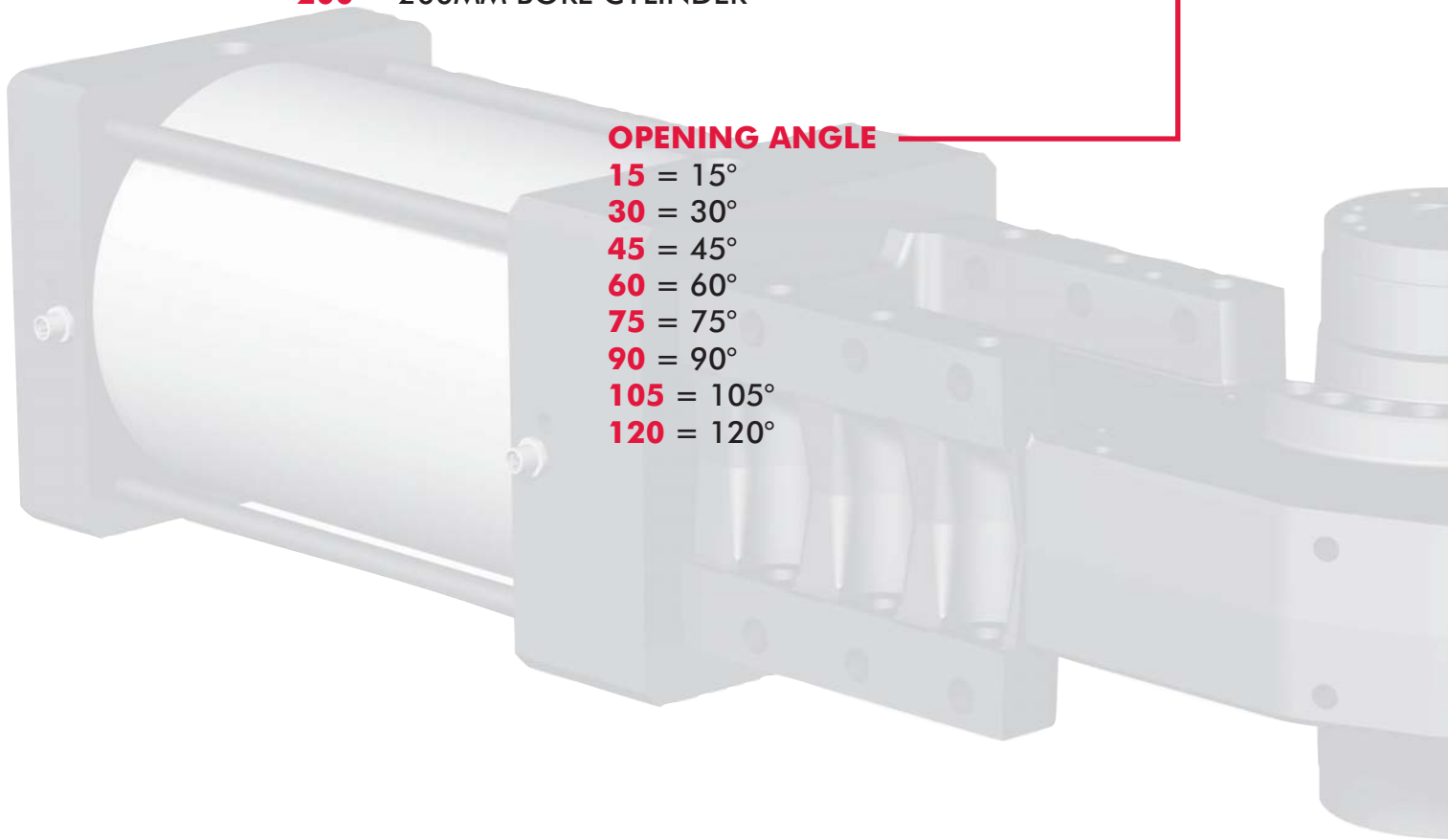
**RU****PNEUMATIC PIVOT MODEL****RU** = RU SERIES PIVOT UNITS  
WITH TOGGLE MECHANISM**200****CYLINDER OPTIONS****125** = 125MM BORE CYLINDER**160** = 160MM BORE CYLINDER**200** = 200MM BORE CYLINDER**90****OPENING ANGLE****15** = 15°**30** = 30°**45** = 45°**60** = 60°**75** = 75°**90** = 90°**105** = 105°**120** = 120°



RU Series Heavy Duty Pivot Units

Ordering Information

0090

X

**CYLINDER POSITION**

- X = CYLINDER POSITION X
- Y = CYLINDER POSITION Y
- W = CYLINDER POSITION W
- Z = CYLINDER POSITION Z

**SADDLE MOUNT BRACKET POSITION**

- 0000 = WITHOUT SADDLE MOUNT BRACKET
- 0090 = (120° MAXIMUM ROTATION)
- 135A = (105° MAXIMUM ROTATION)
- 135B = (120° MAXIMUM ROTATION)
- 180A = (60° MAXIMUM ROTATION)
- 180B = (120° MAXIMUM ROTATION)

RU Series Optional Cylinder Position

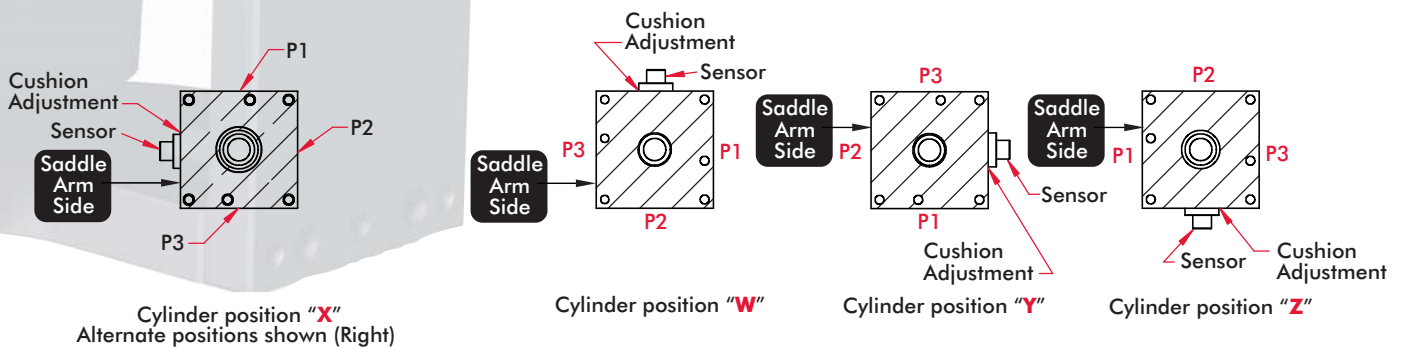

RU Series Heavy Duty Pivot Units

125mm Cylinder Bore Pivot Dimensions

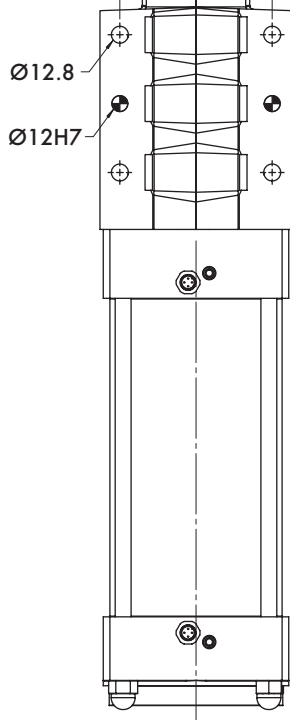
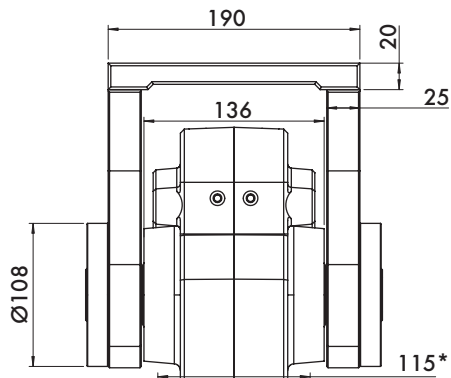
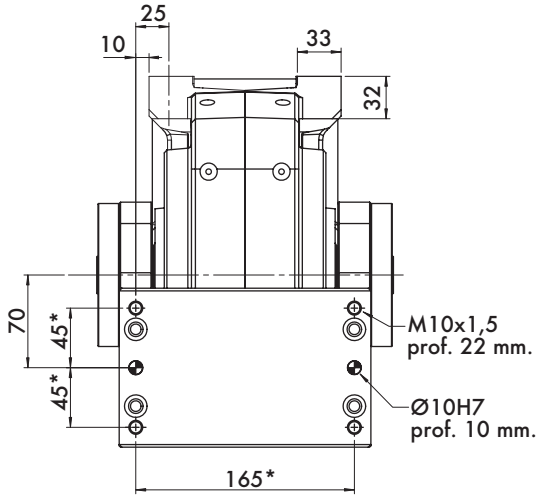

\* Tolerance for dowel holes : ± 0.02  
Tolerance for screw holes : ± 0.1

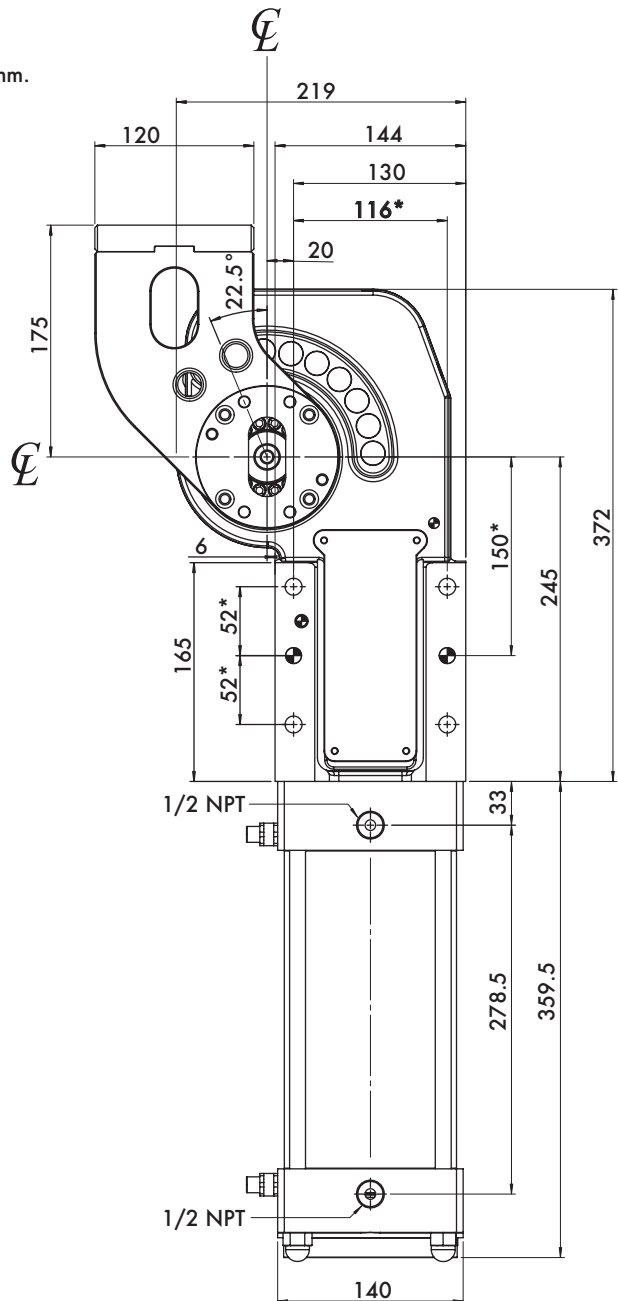



RU Series Heavy Duty Pivot Units

160mm Cylinder Bore Pivot Dimensions

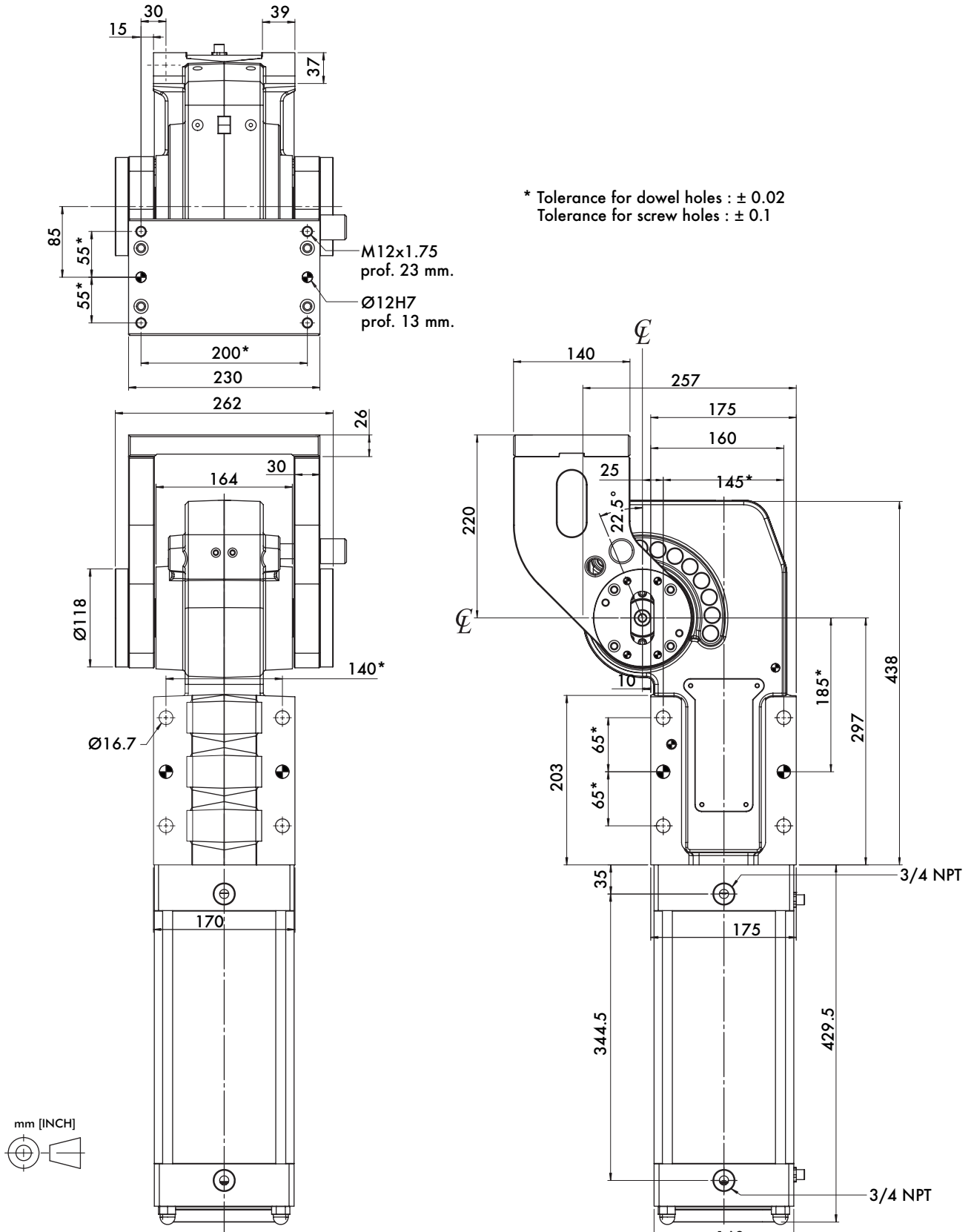

RU Series Heavy Duty Pivot Units

200mm Cylinde Bore Pivot Dimensions

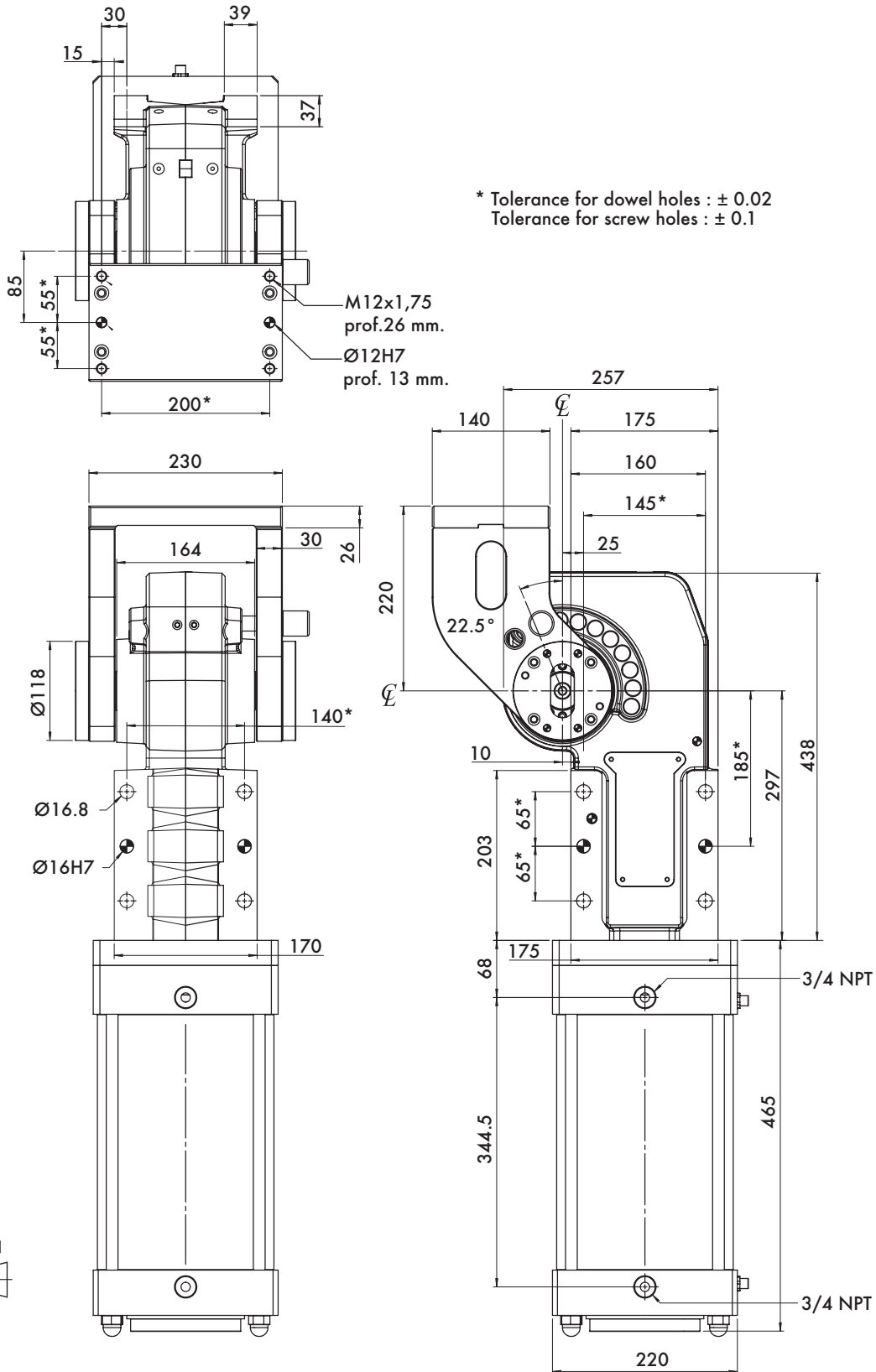

**RU Series Heavy Duty Pivot Units**

**Saddle Arm Mount Bracket Positions**

Saddle Arm Mount has five different start positions Available with starting position angles of 90°, 135° and 180°. The 90° starting position is only offered in a forward position. 135° and 180° starting positions may be offered in a forward position or in an inverted position.



**90 Mount Style**  
90° Forward Bracket Position  
120° Maximum Rotation



**135A Mount Style**  
135° Forward Bracket Position  
105° Maximum Rotation



**135B Mount Style**  
135° Inverted Bracket Position  
120° Maximum Rotation

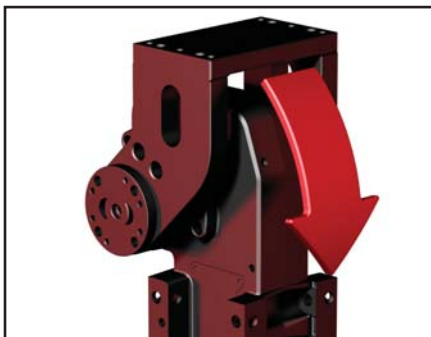

**180A Mount Style**  
180° Forward Bracket Position  
60° Maximum Rotation



**180B Mount Style**  
180° Inverted Bracket Position  
120° Maximum Rotation

RU Series Heavy Duty Pivot Units

Hydraulic-Pneumatic Cylinder

Operating Principle

The RU Series pivot unit utilizes a hydraulic rod system completely contained within the pneumatic cylinder rod to control the mass moved by the pivot unit. The system works with hydraulic oil passing through an orifice in the fixed hydraulic piston rod between chambers within the hydro-pneumatic piston rod. The system has a fixed orifice and does not need adjustment. This system provides constant speed, eliminating sudden movement and abrupt impact at the end of stroke.

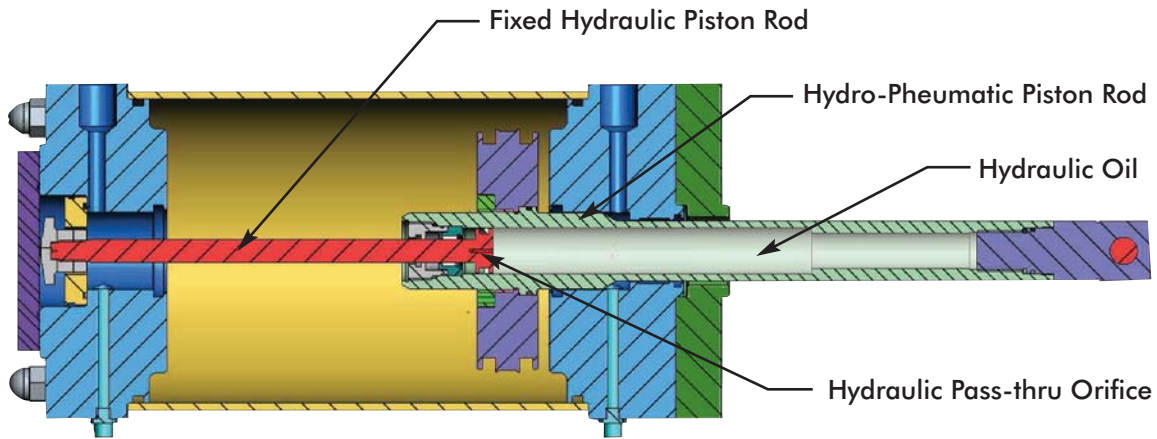

Hydraulic-Pneumatic Cylinder - Dimensions and Cylinder Orientation

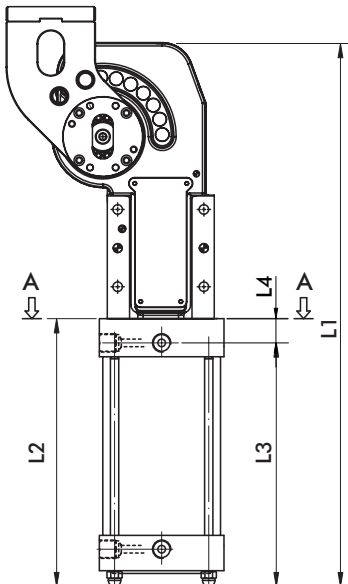
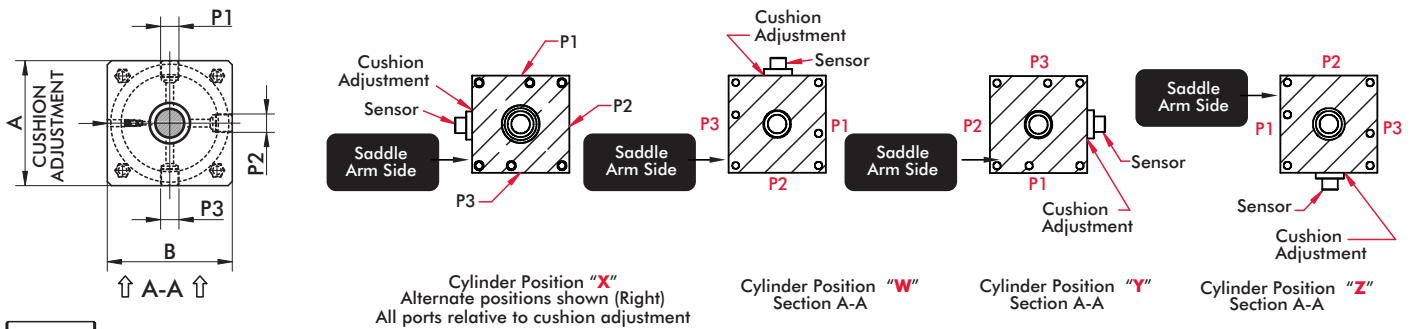

Model	Arm Position	Max. Arm Opening	L1	L2	L3	L4	A - B	P1,P2,P3	Weight
RU125	90	120°	731.5	359.5	278.5				
RU125	135A	105°	713.5	341.5	260.5				
RU125	135B	120°	731.5	359.5	278.5	33	140	1/2" NPT	58 kg [128 lb]
RU125	180A	60°	657.5	285.5	204.5				
RU125	180B	120°	731.5	359.5	278.5				
RU160	90	120°	867.5	705	344.5				
RU160	135A	105°	849.5	733	326.5				
RU160	135B	120°	867.5	741	344.5	35	168	3/4" NPT	100 kg [220 lb]
RU160	180A	60°	793.5	665	270.5				
RU160	180B	120°	867.5	714	344.5				
RU200	90	120°	903	465	344.5				
RU200	135A	105°	885	447	326.5				
RU200	135B	120°	903	465	344.5	68	220	3/4" NPT	122 kg [269 lb]
RU200	180A	60°	829	391	270.5				
RU200	180B	120°	903	465	344.5				



**RU Series** Heavy Duty Pivot Units

Force Charts for Opening Angles

Lifting Applications

**RU SERIES 125MM UNIT (LIFTING APPLICATIONS)**

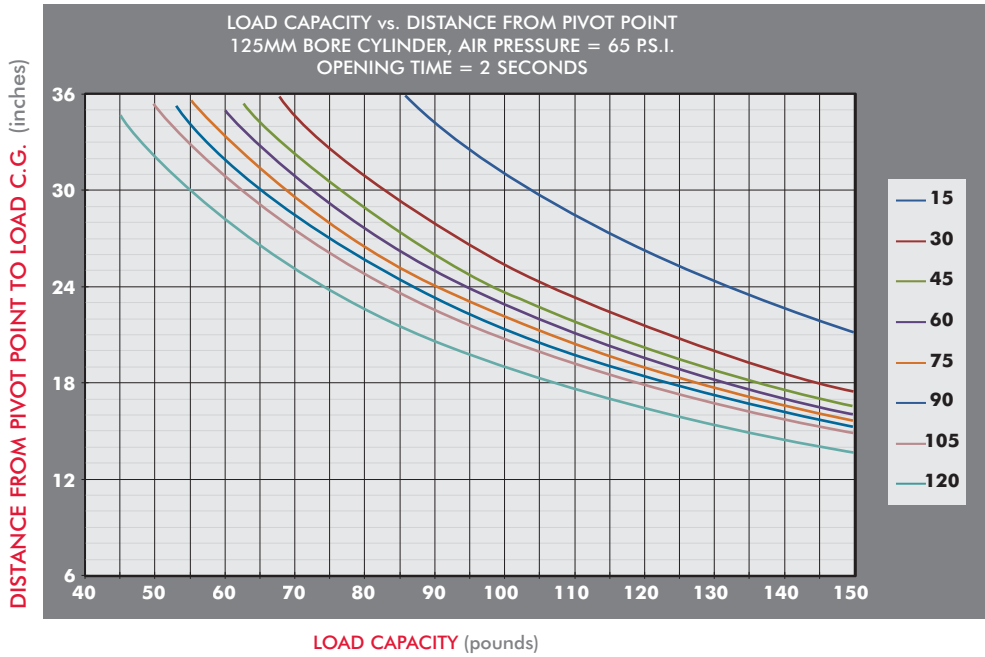

**RU SERIES 160MM PIVOT UNIT (LIFTING APPLICATIONS)**

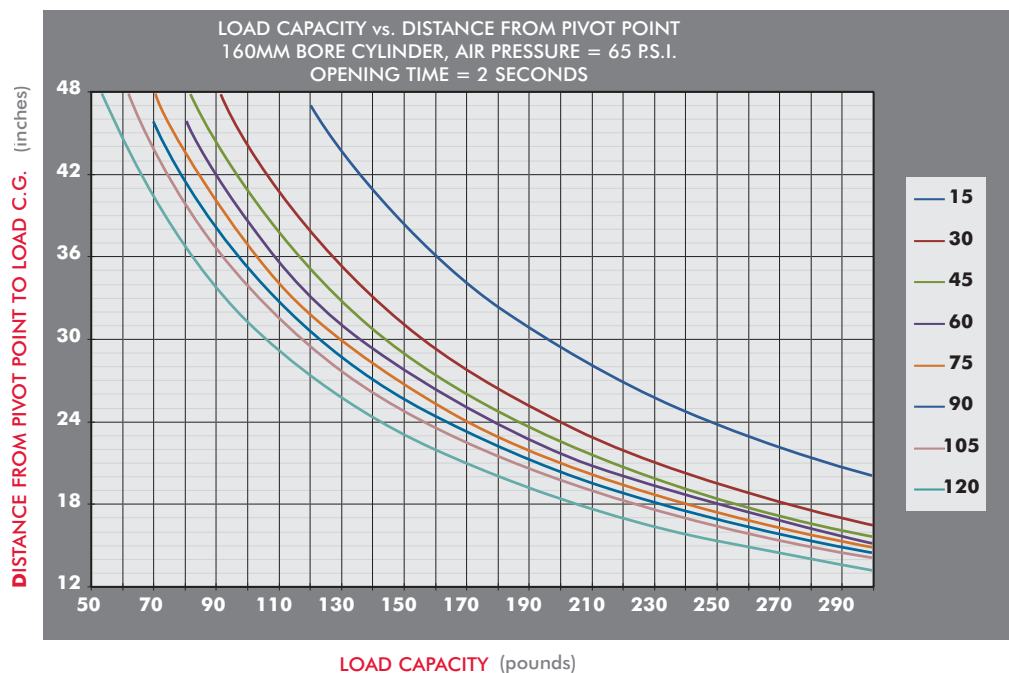



### RU Series Heavy Duty Pivot Units

### Force Charts for Opening Angles

### Horizontal/Rotating Applications

**RU SERIES 125MM PIVOT UNIT (HORIZONTAL APPLICATIONS)**

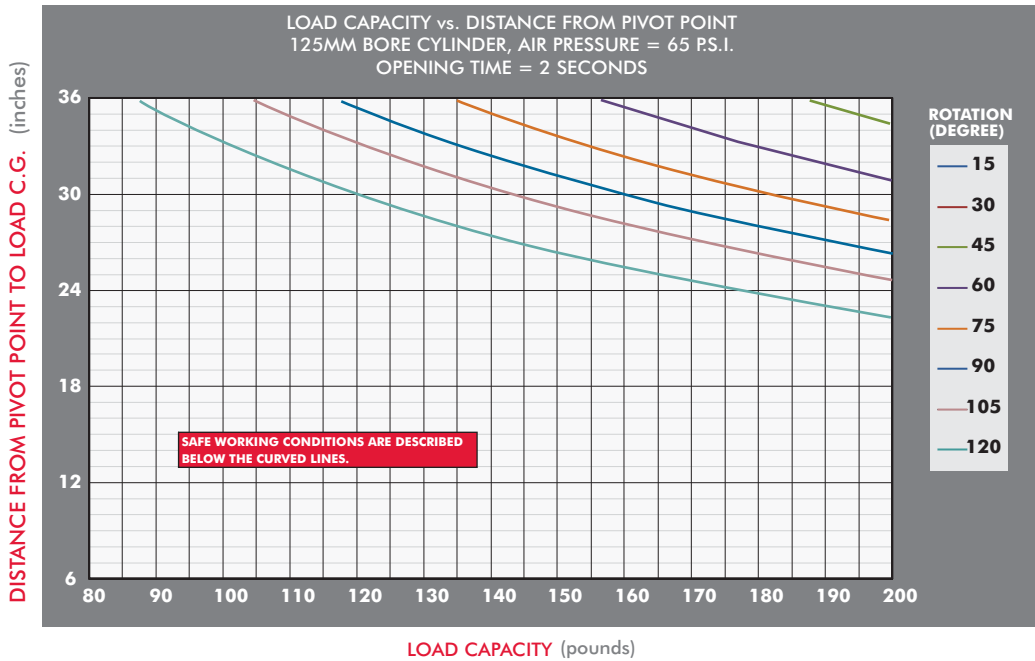

**RU SERIES 160/200MM PIVOT UNIT (HORIZONTAL APPLICATIONS)**

